

Connecting and supporting technology
for **building and infrastructure.**



NORMA **INFRASTRUCTURE**

CONSTRUCTION

SANITARY

WATER MANAGEMENT

SHIPBUILDING



CONNECTING SOLUTIONS **FOR DECADES**

Commercial vehicles



Engines



Infrastructure / Water management



Aviation



Construction equipment



NORMA Group is a global market and technology leader with strong growth prospects in attractive niche markets for engineered joining technologies.

The company manufactures and sells a wide range of high-quality engineered joining technology solutions in three product categories: **clamp**, **connect** and **fluid**. These are often mission-critical for the performance, reliability and quality of the respective customer end products.

Headquartered in Maintal, Germany, NORMA Group has a global network, which includes 17 manufacturing and distribution facilities as well as ten sales and distribution sites across Europe, the Americas and Asia Pacific.

The company offers more than 35,000 high-quality products and solutions to approximately 10,000 customers in a wide range of industries, including agricultural machinery, commercial vehicles, construction equipment, engines, aviation, infrastructure/construction/water management, passenger vehicles, railway, white goods, wholesalers and technical distributors.

Agricultural equipment

Shipbuilding

White goods

Passenger vehicles

Railways



WORLDWIDE PRESENCE

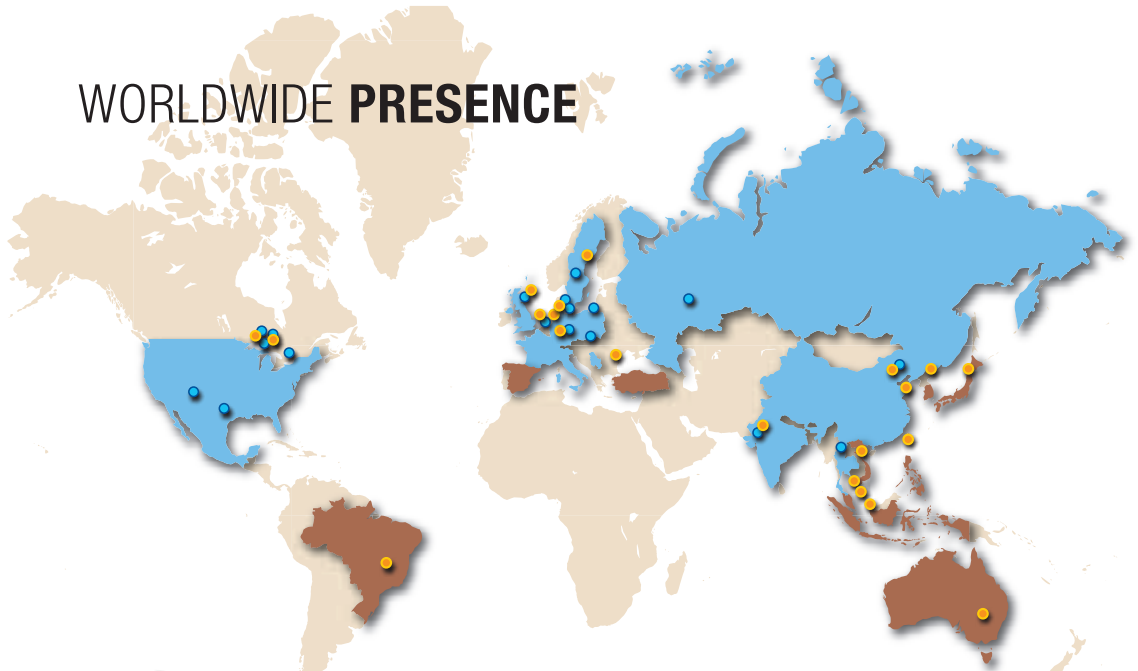

● Manufacturing locations

- China
- Czech Republic
- France
- Germany
- India
- Italy
- Mexico
- Poland
- Russia
- Serbia
- Sweden
- Thailand
- UK
- USA

● Sales and distribution centres

- Australia
- Brazil
- China
- France
- Germany
- India
- Indonesia
- Italy
- Japan
- Malaysia
- Philippines
- Singapore
- South Korea
- Spain
- Sweden
- Switzerland
- Turkey
- UK
- USA
- Vietnam

NORMA INFRASTRUCTURE

NORMA INFRASTRUCTURE a division within NORMA Group, supplying technical added value solution for connecting, supporting and fixing for building and infrastructure.

CONSTRUCTION



WATER MANAGEMENT



PIPELINES



SANITARY



SHIP BUILDING



OUR MISSION => **100% SECURITY FOR YOUR PROCESS**

ORIENTED: our orientation is to secure your process by delivering global solution.

RESPONSIBLE: our products are fully tested to meet your quality requirements.

ADVANTAGE: our global solutions enable customers to be innovative and competitive on their markets.

CUSTOMER: we are fully dedicated to your individual satisfaction – wholesalers and end-users.

LEARNING: our solution development is driven by your feedback.

EXPERT: our know-how and competencies allows us to respond to your applications.

NORMA QUALITY

Quality issues are of great concern to the NORMA Group. With a strong quality department and a well implemented quality and environmental management system within our production units we ensure high performance of our products and customers satisfaction.

LABORATORY

Our laboratory is equipped to conduct life cycle and approvals testing for all relevant applications such as Water management, Shipbuilding, Construction and Sanitary – and also for other industries. Tests following ISO Standards can also be done in our laboratory.

CERTIFICATES

Within the NORMA Group we maintain the following certificates:

- ISO 9001
- ISO 14001
- ISO/TS 16949
- EN 9100 for the aviation industry
- ISO/TS 19646
- DQS Quality Management System and 2.2 Test Certificates

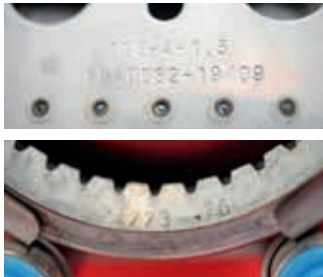

TRACEABILITY



KNOW-HOW



TESTING

EXAMPLES OF INTERNATIONAL APPROVALS



Certified and/or approved in compliance with:
 TS 16949
 DIN EN ISO 9001
 EAQF • FORD Q1
 DIN EN ISO 14001

NORMA INFRASTRUCTURE – IN LINE WITH YOUR NEEDS

NORMA INFRASTRUCTURE offers a wide range of solutions for needs you face on the field. See, on the next pages, more details about our solutions which are suitable to your applications.

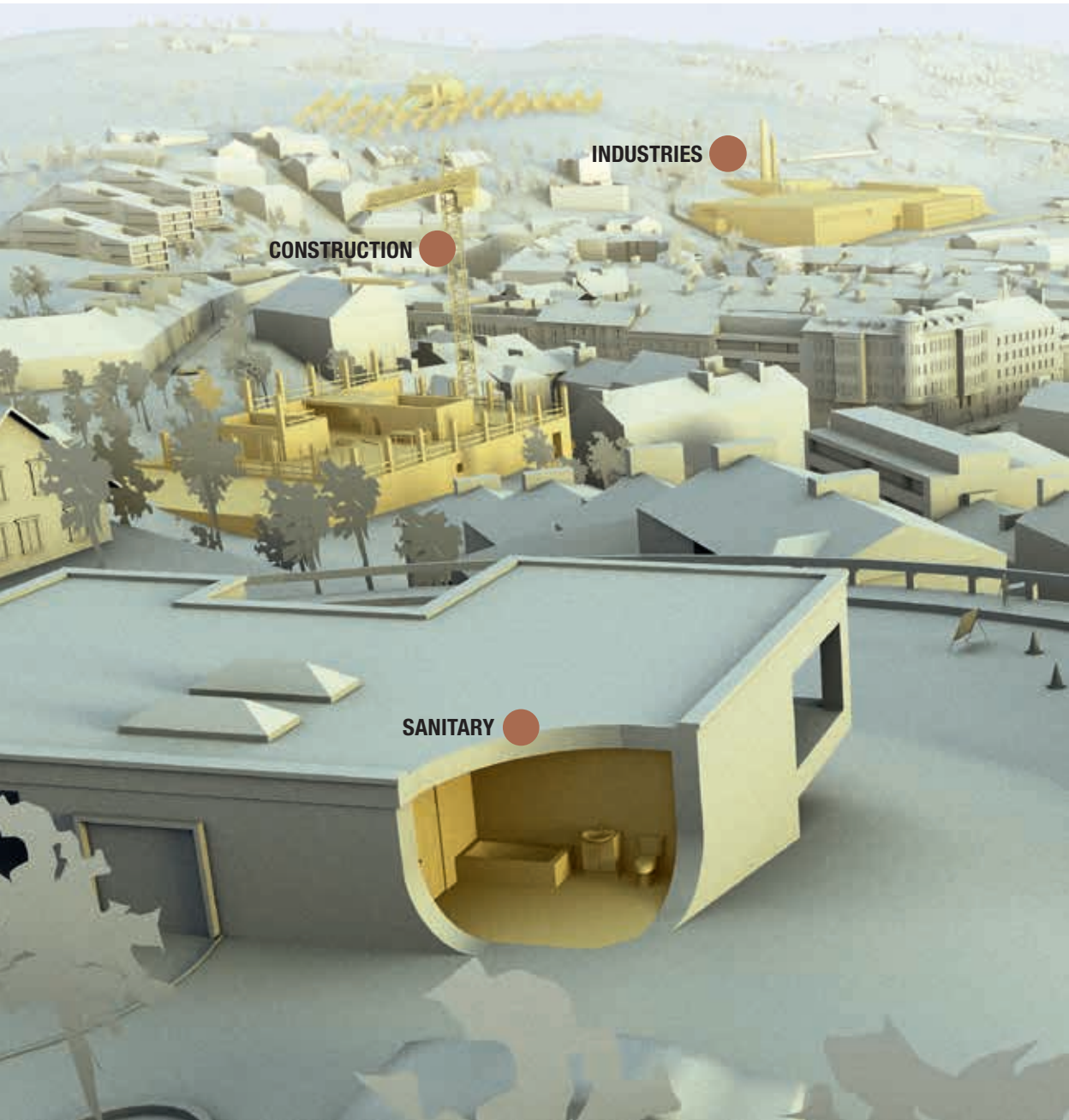

CONSTRUCTION

INDUSTRIES

SANITARY

● WE ARE **HERE**

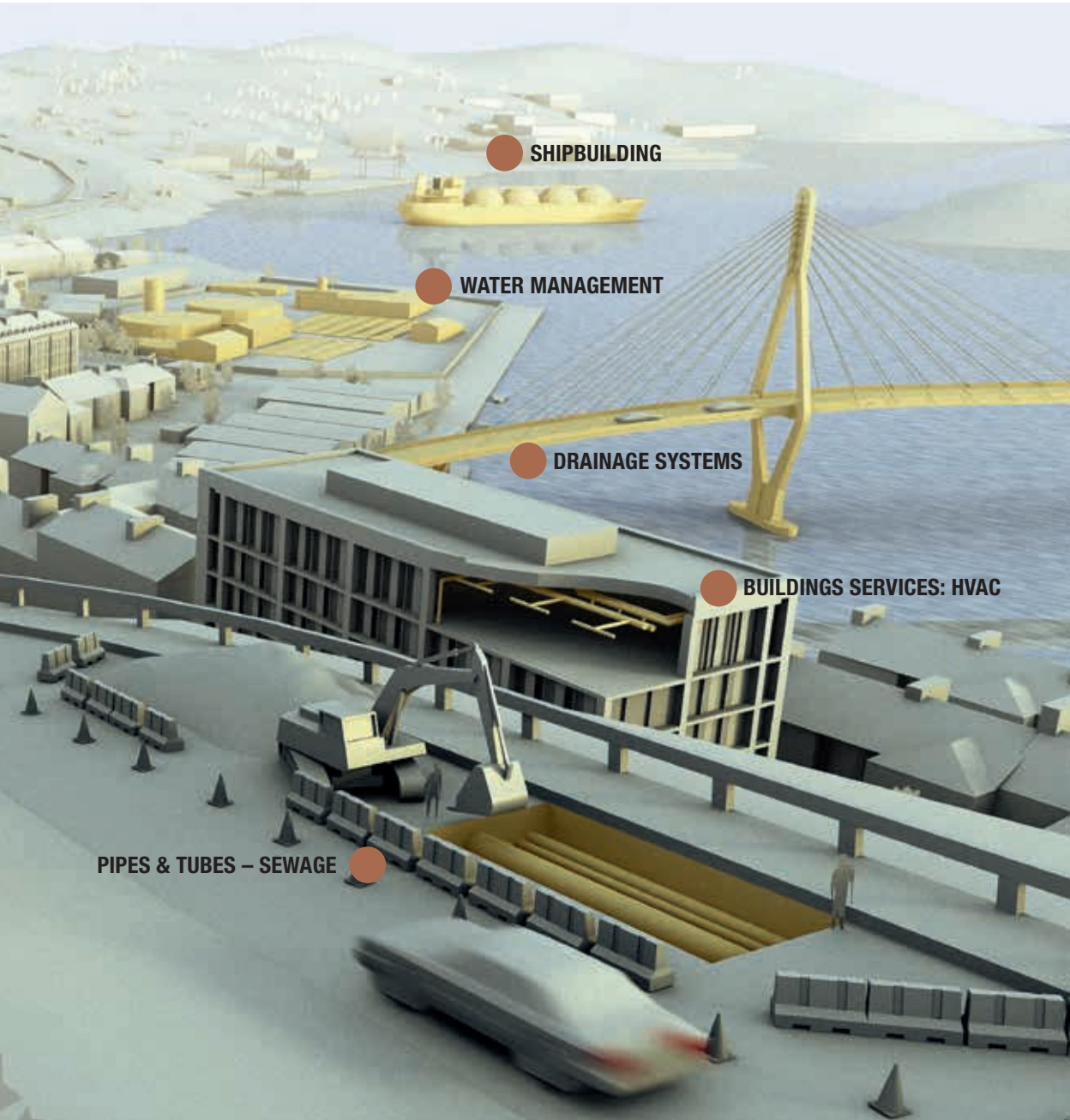

● SHIPBUILDING

● WATER MANAGEMENT

● DRAINAGE SYSTEMS

● BUILDINGS SERVICES: HVAC

PIPES & TUBES – SEWAGE ●

OUR SOLUTIONS FOR **CONSTRUCTION**

NORMA INFRASTRUCTURE provides ready to install and time saving solutions. Securing your installations with our reliable connecting, supporting and fixing offer.

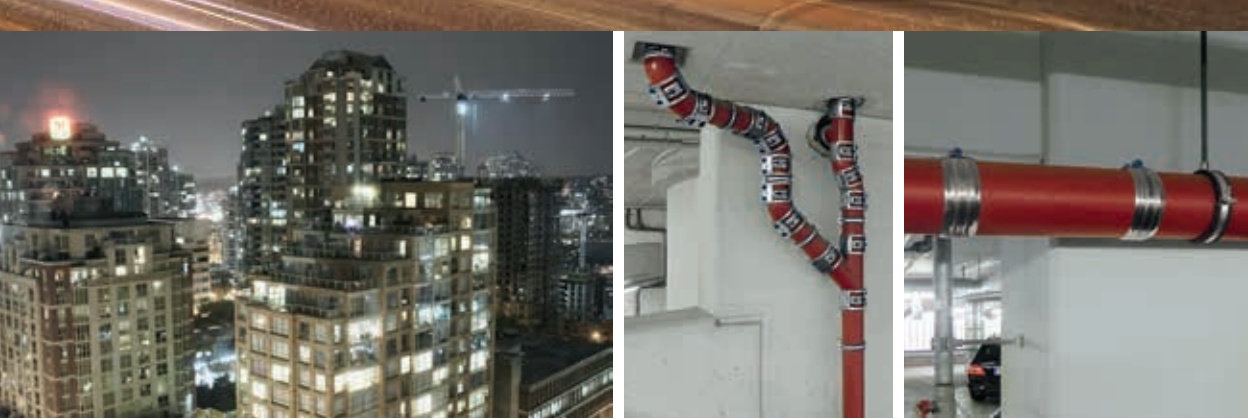

BUILDING

- **DCS range:** RAPID, CV, Universal Claw
- **FGR range:** PLAST GRIP E
- **PSS range:** Channels, Isophonic Pipe Clamps, Beam Clamps

PUBLIC WORKS

- **DCS range:** RAPID, CV, Universal Claw

PIPES & TUBES

- **DCS range:** RAPID, CV, Universal Claw
- **FGR range:** FLEX E, FLEX 3
- **PSS range:** Isophonic Pipe Clamps, Cantilevers

TRANSPORT

- **FGR range:** GRIP, FLEX
- **PSS range:** Isophonic Pipe Clamp, Heavy Duty Pipe Clamp

MACHINERY

- **FGR range:** GRIP E
- **PSS range:** Isophonic Pipe Clamp, Cable Tie

OUR SOLUTIONS FOR **WATER MANAGEMENT**

Our solutions offer guarantees for your installation: leakage proofing, ready to install, process resistant, hygienic, durability and flexibility.

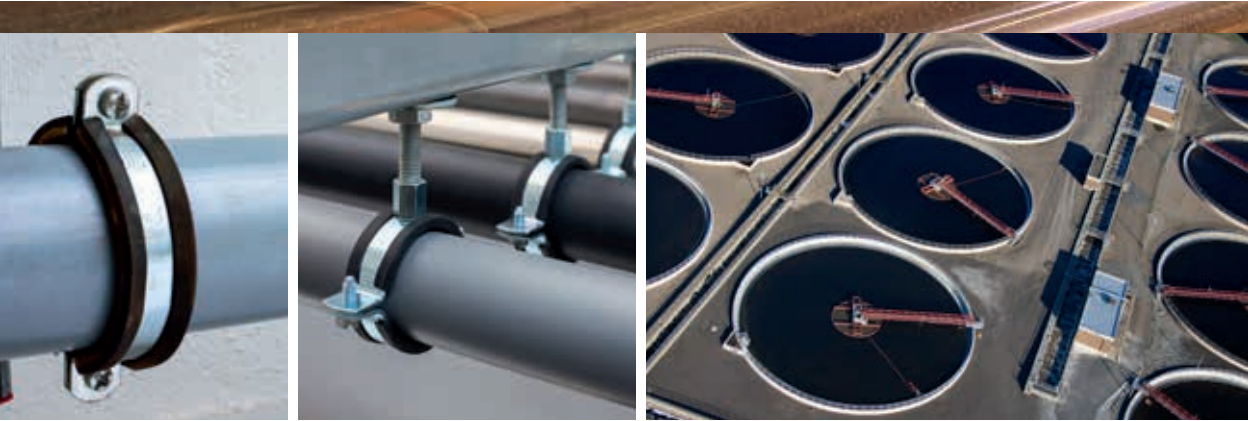

WATER CATCHING

- **FGR range:** FLEX, REP E

SUPPLY / TRENCH

- **FGR range:** PLASTIC GRIP E

CONSUMERS

- **PSS range:** Plastic clips, Isophonic Pipe Clamps

SEWAGE

- **DCS range:** RAPID, CV, Universal Claw
- **FGR range:** GRIP E

OUR SOLUTIONS FOR **SANITARY**

Our solutions provide to SANITARY sector easy & quick installation systems and long term reliability, flexibility regarding pipes material and dimensions.



DRAINAGE

- **DCS range:** RAPID, CV, Universal Claw
- **PSS range:** Gutter Pipe Clamps

WATER SUPPLY

- **FGR range:** FLEX, FLEX3
- **PSS range:** Plastic Clips, Isophonic Pipe Clamps

HVAC

- **PSS range:** Insulated Pipe Clamps, Cantilevers

OUR SOLUTIONS FOR SHIPBUILDING

Ships are complex technological environment (vibration, corrosion, pressure, flow, fire security, space and weight constraints), we ensure you to have a reducing global cost solution for approved shipbuilding applications.



BALLAST LINE

- FGR range: GRIP E-FP

FRESH WATER

- FGR range: GRIP E

COOLING WATER

- FGR range: PLAST GRIP E, GRIP E

OILS

- FGR range: GRIP E-FP

BILGE LINE

- FGR range: GRIP E-FP

TECHNICAL WATER

- FGR range: COMBI GRIP E

INDEX

FGR



Intro

Our solution, approvals, etc 16

For axial non-restraint connections

FLEX/FLEX E 26
FLEX 3 28
REP E 30

For axial restraint connections

GRIP/GRIP E 34
GRIP/GRIP E-FP 37
PLAST GRIP / PLAST GRIP E 40
COMBI GRIP / COMBI GRIP E 42
Accessories 44

DCS



Intro

Our solution, certificates, etc 48

For non pull-out resistant connections

DCS RAPID 54
DCS RAPID MSM 55
DCS CV/CE 56
DCS SVE 57

For pull-out resistant connections

DCS UNIVERSAL Restraint Collar 60
DCS REKORD Restraint Collar 61
DCS KOMBI Restraint Collar 62

Changeover connectors

DCS FIX 64
Survey of sizes 65

PSS



Intro

Our solutions, certificates, etc 68

Non Isophonic Pipe Clamps

Pipe clamp M8/M10 with captive screws .. 72
Heavy duty pipe clamp M12 73
Drain pipe clamp M8 74
Sprinkler pipe clamp 75
Bridge pipe clamp 76
Conduit clip 77

Isophonic Pipe Clamps

Isophonic quick clamp with hinge
M8/M10 80
Isophonic quick clamp with hinge
and fixing M8/M10 81
Isophonic pipe clamp M8/M10 with
captive screws 82
Isophonic heavy duty pipe clamp M12 84
M8 isophonic gutter pipe clamp 85
Bridge isophonic pipe clamp 86
Insulated pipe clamp 13 mm-M8/M10 87
Insulated pipe clamp 19 mm-M8/M10 88

Plastic Clip

Simple & double plastic clip M6 90

Channels

Channel 27/18 C-shape 93
Channel 28/30 C-shape 93
Channel 38/40 C-shape 94
Cantilever 27/18 C-shape 95
Cantilever 28/30 C-shape 96
Channel screw for C-shape channel 97
Fixing plate for C-shape channel 98
Vertical & horizontal support for
C-shape channel 99
Channel 41/21 strut 41-shape 101

PSS



Channel 41/41 strut 41-shape	102
Cantilever 41/21 strut 41 shape	103
Cantilever 41/41 strut 41 shape	104
U plate for strut 41 shape	105
Channel nut for strut 41 shape	105
Channel screw for strut 41 shape	106
135° fixing plate for strut 41 shape	107
90° fixing plate for strut 41 shape, 2 slots	107
90° fixing plate for strut 41 shape, 3 slots	108
Reinforced square for strut 41 shape 4 slots	108
Double base for strut 41 shape	109
Bridge 5 slots for strut 41 shape	109
Beam clamp M10 for strut 41 shape....	110
C & strut 41 shape channel connection..	111
Caps for c ans strut 41 shape channel ..	112

Accessories

Threaded screws.....	116
Double thread screw.....	116
Hexagonal nut.....	117
Large washer	117
Screw anchor.....	118
Wedge anchor.....	118
Brass anchor	119
Drop-in anchor.....	119
Threaded rod	120
Threaded pins.....	120
Double threaded screw	121
Elevation nut.....	121
Coupling nut	122
Round base plate	123
Perforated band	124
Cable tie –White and Black	125
Cable tie – Colors.....	126

PSS

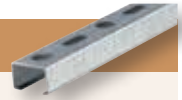

Tie mount plug	126
Screw mount & adhesive pad	127
Pliers for cable tie PA 6.6.....	128
Pliers for cable tie PA 6.6 and PA 12 ...	128

Fixing on steel structure

Beam clamp	131
Threaded rod horizontal clip	132
Cable tie horizontal clip.....	133
Perforated band horizontal clip	134
Threaded rod vertical clip.....	135
Cable tie vertical clip	136
Perforated band vertical clip.....	137
Beam clip	138

Stainless Steel Supporting and Fixing

Stainless steel pipe clamp M8/M10 with captive screws	140
Stainless steel channel 28/30 C-shape ..	141
Stainless steel channel 38/40 C-shape ..	141
Stainless steel channel screw for C-shape channel	142
Stainless steel fixing plate for C-shape channel	143
Stainless steel double threaded screw..	144
Stainless steel hexagonal nut	144
Stainless steel large washer	145
Stainless steel threaded rod	145
Stainless steel rectangular base plate...	146
Stainless steel band	146
Technical information.....	147

ADDITIONAL SOLUTIONS

NORMACLAMP®	164
Market development.....	166

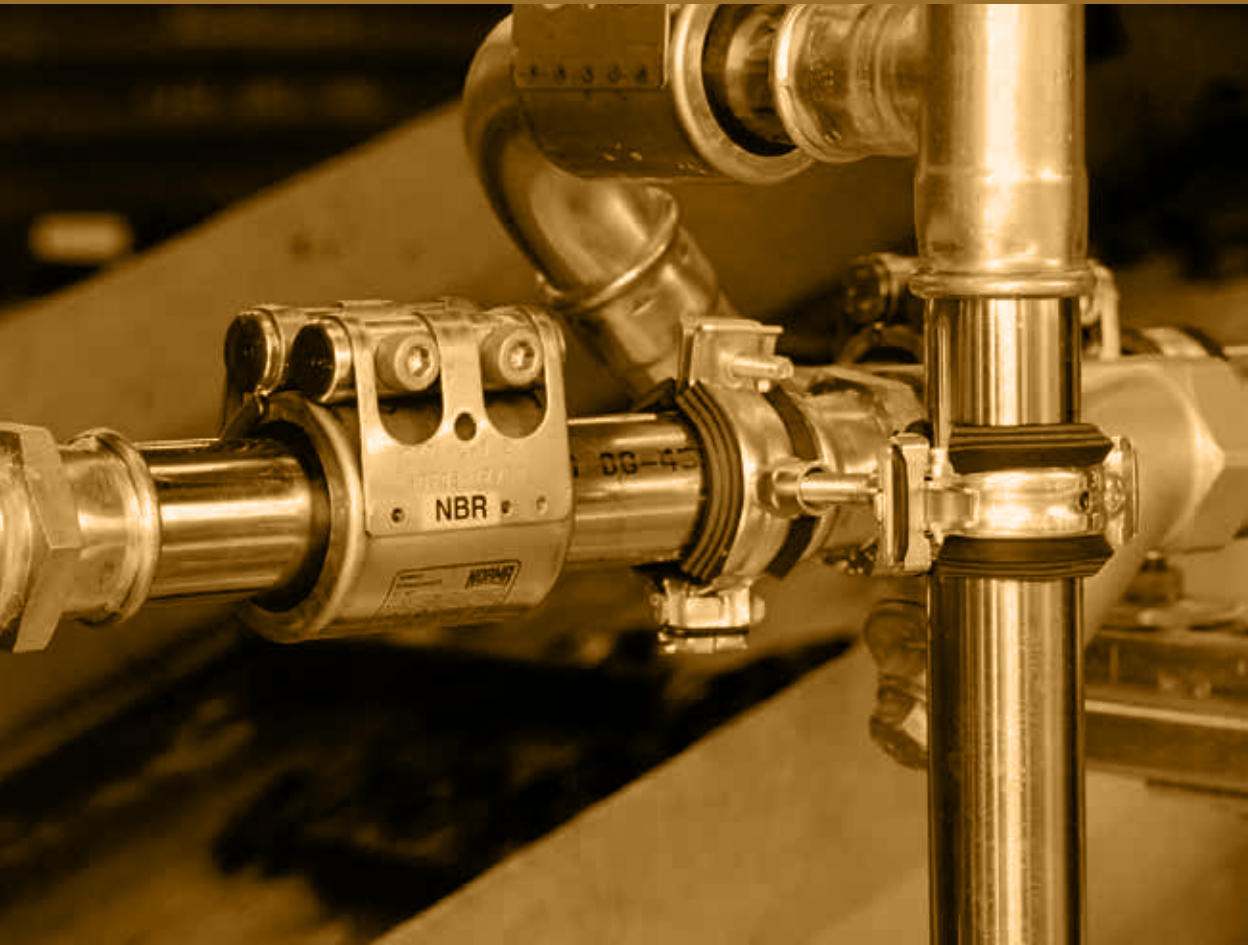



FGR



OUR SOLUTION FOR CONNECTING – FGR

FGR pipe couplings are a compact, economical and reliable means for connecting plain-ended pipes. They are suitable to join plastic and metal pipes and especially pipes made from stainless steel. They can be used in mechanical engineering and construction, shipbuilding, civil engineering and in hydro technology.

Supply pipes as well as exhaust pipes for solid, liquid or gaseous media can be joined easily and safely in a very short period of time even in narrow spaces.

Thanks to the wide range of various types and sizes they are suitable for use both in standard and specialized applications.

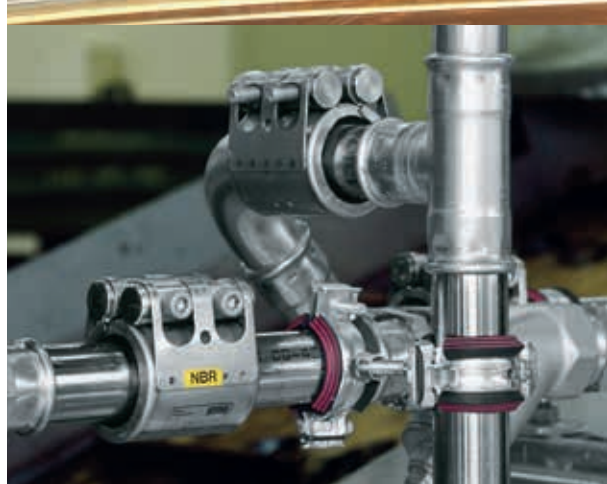

APPROVALS

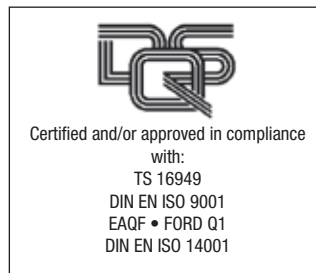



PRODUCT BENEFITS



FGR pipe couplings are an economical alternative to conventional pipe joining techniques for both plastic and metal pipes. All plain-ended pipes can be joined easily by hand. The ready to fit coupling is pushed over the pipe ends and then aligned and rotated to any fitting position. Tightening the two bolts alternately with a torque wrench is all it takes to make a safe fitting.

RANGE OF APPLICATIONS

FGR pipe coupling is a reliable connection for thick- and thin-walled pipes which conforms to the latest DIN Standard 86128. Feed and return lines for liquids, gas and solids (for mechanical engineering and construction, civil engineering, shipbuilding, pipeline construction, power stations, mining, filters, water technology, etc.) are joined quickly, easily and safely using FGR pipe couplings.

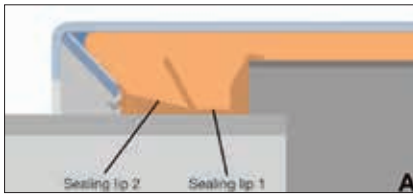

1. DOUBLE-LIP SEALING SYSTEM

The patented double-lip sealing system (Fig. A) of the FGR pipe couplings offers double safety; It provides maximum sealability at both low and high operating pressures.

When the bolts of the coupling are tightened sealing lip 1 is pressed onto sealing lip 2, thus providing a highly reliable seal even under the condition of low pressures, vacuum or extreme loads acting on the joint (Fig. B).

The special sealing lip design means that when the internal pressure (P) increases, the sealing lips are pressed more firmly onto the pipe surface ensuring an even stronger seal (Fig. C).



No welding

No necessity of prior pipe alignment or treatment of the pipe ends

Up to 80% time saving



Pipe gaps up to 35 mm possible

Axial movements up to 7.5 mm

Misalignment up to 3 mm



Less than 70% weight



Angular deflection up to 4° in total

2. STANDARD STRIP INSERT

All FGR pipe couplings are factory equipped with the standard strip insert (2). The strip insert protects the sealing sleeve from increased mechanical and chemical loads. It also prevents the sealing sleeve from moisture expansion and allows larger gaps between the pipe ends to be connected.

Furthermore, it allows larger angular deflections and misalignment. With the strip insert the couplings can also be used for both vacuum and high pressure applications without any problems. The strip inserts are made from plastic material or stainless steel.

3. HEAVY DUTY LOCK BARS

For FGR pipe couplings we use lock bars (3) with a larger diameter. Thus the rigidity of the coupling is increased and the engagement of the threaded end of the locking bolts is considerably improved.

4. ANCHORING RING WITH CONICALLY STAMPED TEETH

The anchoring ring (4) with conically stamped teeth indents into the pipe surface and provides safe and strong axial restraint. Owing to the special design the coupling is able to withstand even high vibration loads.

5. PROTECTION RING

The protection ring protects the sealing sleeve from UV rays, fire, etc. and increases the flexural strength of the coupling.

PRODUCT TYPES

The FGR product range features the correct coupling for any conceivable application. The current range of pipe couplings comprises the following types:

FGR – for axial non-restraint connections:



FLEX/FLEX E

Axial non-restraint pipe couplings used to connect metal and/or plastic pipes



FLEX 3

Axial non-restraint pipe couplings used to connect metal and/or plastic pipes; extra wide band



REP E

Repair couplings used to connect and seal restrained metal and plastic pipes

FGR – for axial restraint connections:



RFP

Retrofitable flame protection for axial restraint and none axial restraint pipe coupling



GRIP/GRIP E

Axial restraint pipe couplings used to connect metal pipes with plastic pipes



GRIP E-FP

Axial restraint pipe couplings with integrated flame protection used to connect metal pipes



PLAST GRIP/PLAST GRIP E

Axial restraint pipe couplings used to connect plastic pipes



COMBI GRIP/COMBI GRIP E

Axial restraint pipe couplings used to connect metal pipes with plastic pipes

COUPLINGS TYPES AND SUITABLE APPLICATIONS

PIPES TO BE JOINED	SIZE (mm)	FLEX	FLEX E	FLEX 3	REP EF from 35 mm
Metal + Metal	26.9 to 168.3	70 to 32 bar	70 to 32 bar	-	60 to 32 bar
	180.0 to 1219.2	50 to 7 bar	30 to 4 bar	-	30 to 4 bar
	326.0 to 2032.0	-	-	16.5 to 1.5 bar	-
Plastic + Plastic	26.9 to 168.3	16 bar	16 bar	-	16 bar
	180.0 to 1219.2	16 to 7 bar	16 to 4 bar	-	16 to 4 bar
Metal + Plastic	26.9 to 168.3	16 bar	16 bar	-	-
	180.0 to 1219.2	16 to 7 bar	16 to 7 bar	-	-

PIPES TO BE JOINED	SIZE (mm)	GRIP	GRIP E	COMBI-GRIP E	COMBI-GRIP	PLAST-GRIP E	PLAST-GRIP
Metal + Metal	26.9 to 168.3	70 to 32 bar	70 to 32 bar	-		-	-
	180.0 to 419.0	-	20 to 2 bar	-		-	-
	180.0 to 711.2	32 to 2.5 bar	-	-		-	-
Plastic + Plastic	40.0 to 168.3	-	-	-		16 bar	-
	200.0 to 406.4	-	-	-	-	-	16 to 6
Metal + Plastic	38/40 to 160/168.3	16 bar	16 bar	16 bar	-	-	-
	200.0/204.0 to 406.0/406.4	-	-		16 to 6	-	-

FGR MATERIALS

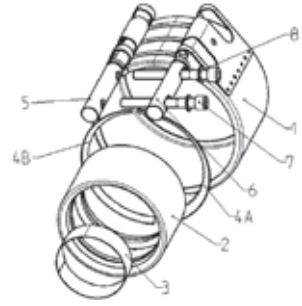

COMPONENTS AND MATERIALS in accordance with AISI/BS.
FGR pipe couplings are available in the materials W2, W4 and W5.

W2				
No.	Component	FLEX/FLEX E	GRIP/GRIP E	PLAST GRIP/ PLAST GRIP E
1	Housing with bridge	304/304 S31	304/304 S31	304/304 S31
2	Sealing sleeve	EPDM/NBR	EPDM/NBR	EPDM/NBR
3	Strip insert ¹⁾	316Ti/320 S31/PA-GR	316Ti/320 S31/PA-GR	316Ti/320 S31/PA-GR
4 A	Anchoring ring for metal pipes ²⁾	–	301/301 S21	–
4 A	Anchoring ring for plastic pipes ²⁾	–	–	PA-GF-NS ³⁾
4 B	Protection ring	316Ti/320 S31	–	–
5 + 6	Solid locking trunnions	AISI 1213	AISI 1213	AISI 1213
5 + 6	Hollow locking trunnions	AISI 1518	AISI 1518	AISI 1518
7	Locking bolts	10,9	10,9	10,9
8	Washer	A4-80/316	A4-80/316	A4-80/316

W4				
No.	Component	FLEX/FLEX E	GRIP/GRIP E	PLAST GRIP/ PLAST GRIP E
1	Housing with bridge	304/304 S31	304/304 S31	304/304 S31
2	Sealing sleeve	EPDM/NBR	EPDM/NBR	EPDM/NBR
3	Strip insert ¹⁾	316Ti/320 S31/PA-GR	316Ti/320 S31/PA-GR	316Ti/320 S31/PA-GR
4 A	Anchoring ring for metal pipes ²⁾	–	301/301 S21	–
4 A	Anchoring ring for plastic pipes ²⁾	–	–	PA-GF-NS ³⁾
4 B	Protection ring	316Ti/320 S31	–	–
5 + 6	Solid locking trunnions	316L	316L	1.4404
5 + 6	Hollow locking trunnions	316Ti/320 S31	316Ti/320 S31	1.4571
7	Locking bolts	A4-80/316	A4-80/316	A4-80
8	Washer	A4-80/316	A4-80/316	A4-80

¹⁾ PA-GF plastic strip inserts are only for pipe couplings used in shipbuilding applications.

²⁾ COMBI GRIP couplings are equipped with two different anchoring rings (1 x for the metal end, 1 x for the plastic end).

³⁾ PA-GF: PA reinforced with fi bre glass; NS: new silver.

W5						
No.	Component	FLEX/FLEX E	GRIP/GRIP E	COMBI GRIP/ COMBI GRIP E	PLAST GRIP/ PLAST GRIP E	REP E
1	Housing	316Ti/320 S31	316Ti/320 S31	316Ti/320 S31	316Ti/320 S31	316Ti/320 S31
2	Sealing sleeve	EPDM/NBR	EPDM/NBR	EPDM/NBR	EPDM/NBR	EPDM /NBR
3	Strip insert ¹⁾	316Ti/320 S31/PA-GR	316Ti/320 S31/PA-GR	316Ti/320 S31/PA-GR	316Ti/320 S31/PA-GR	316Ti/320 S31/PA-GR
4 A	Anchoring ring for metal pipes ²⁾	–	301/301 S21	301/301 S21	–	–
4 A	Anchoring ring for plastic pipes ²⁾	–	–	PA-GF-NS ³⁾	PA-GF-NS ³⁾	–
4 B	Protection ring	316Ti/320 S31	–	–	–	–
5 + 6	Solid locking trunnions	316L	316L	316L	316L	316L
5 + 6	Hollow locking trunnions	316Ti/320 S31	316Ti/320 S31	316Ti/320 S31	316Ti/320 S31	316Ti/320 S31
7	Locking bolts	A4-80/316	A4-80/316	A4-80/316	A4-80/316	A4-80/316
8	Washer	A4-80/316	A4-80/316	A4-80/316	A4-80/316	A4-80/316

¹⁾ PA-GF plastic strip inserts are only for pipe couplings used in shipbuilding applications.

²⁾ COMBI GRIP couplings are equipped with two different anchoring rings (1 x for the metal end, 1 x for the plastic end).

³⁾ PA-GF: PA reinforced with fibre glass; NS: new silver.

SEALING SLEEVES: Areas of application & temperature resistance

MATERIAL OF SEAL	EPDM	NBR
Temperature range	–30 °C up to +125 °C OD 26.9 up to 168,3 mm –20 °C up to +80 °C OD > 180 mm	–20 °C up to +80 °C
Media	Drinking water Alcohols Compressed air Solids	Water Oils Gases (combustible) Fuels Hydrocarbon solutions





For axial non-restraint connections



FLEX/FLEX E pipe couplings are used for connecting restrained pipes, metal pipes stainless pipes as well concrete and plastic pipes can be connected. With FLEX/FLEX E couplings sealing reliability is also ensured under conditions of gaps between pipe ends which are compensated.

FLEX/FLEX E couplings could be compensated axial movements /change in length of straight pipe connections, according to the size of coupling between 5 up to 15mm. FLEX/FLEX E are able to compensate.

● FLEX/FLEX E

The protective pipe coupling



- 1 Double-lip sealing system
- 2 Standard strip insert
- 3 Heavy duty lock bars
- 4 Protection ring

ADVANTAGES Compensation of pipe gaps allows thermal elongation of the pipes. Joining all kind of pipe materials are possible for example steel, plastic, cast iron and others.

TECHNICAL DATA

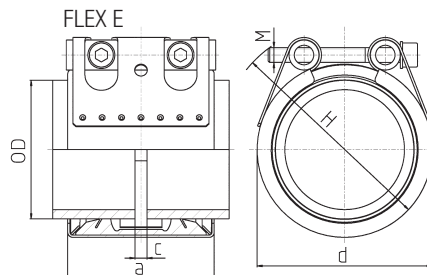
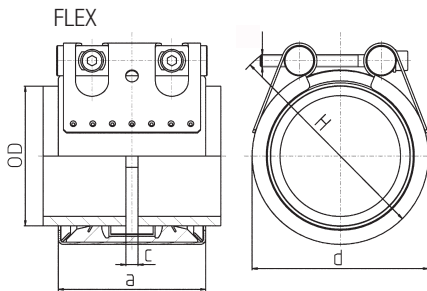

Sizes: 26,9 mm - 1219,1 mm
 Working pressure: 70,0 - 7,0 bar
 Material: AISI 304, AISI 316 Ti
 EPDM:
 Sizes from 26,9 mm up to 168,3 mm: - 30 °C up to + 125 °C.
 Sizes > 180,0 mm: - 20 °C up to + 80 °C
 NBR: from - 20 °C up to + 80 °C

DIMENSIONS



FEATURES

FLEX/FLEX E couplings are used for connecting restrained pipes. Given outside pipe diameters of > 180 mm the Flex type is suitable for high pressure and the Flex E type for low pressure applications.

OD	Clamping range		PN ¹⁾  (bar)	WP ²⁾  (bar)	C _{max} (mm)	Dimensions		
	ODmin	– ODmax				a	d clamped approx. (mm)	H approx. (mm)
(mm)	(mm)		(bar)	(bar)	(mm)	(mm)	(mm)	(mm)
26.9	26.4	– 27.5	16	70	3	67	50	70
28.0	27.5	– 28.5	16	70	3	67	50	70
30.0	29.5	– 30.6	16	70	3	67	50	70
33.7	33.0	– 34.3	16	60	3	67	55	75
35.0	34.5	– 35.6	16	60	8	63	55	75
38.0	37.5	– 38.6	16	60	8	63	60	80
42.4	41.7	– 43.0	16	50	8	63	65	85
44.5	44.0	– 45.1	16	50	8	63	65	85
48.3	47.6	– 50.5	16	50	8	63	70	90
54.0	53.3	– 54.6	16	50	17	78	75	95
57.0	56.3	– 57.7	16	50	17	78	80	100
60.3	59.5	– 61.0	16	40	17	78	85	105
63.0	62.2	– 63.9	16	40	17	78	85	105
70.0	69.0	– 71.0	16	40	25	98	90	110
73.0	72.1	– 73.8	16	40	25	98	95	115
76.1	75.2	– 77.0	16	35	25	98	100	120
78.0	77.1	– 78.9	16	35	25	98	100	120
80.0	79.0	– 80.8	16	35	25	98	100	120
84.0	83.0	– 85.0	16	35	25	98	105	125
88.9	87.0	– 89.9	16	35	25	98	110	130
101.6	100.4	– 102.8	16	35	25	98	125	145
104.0	102.8	– 106.1	16	35	25	98	125	145
108.0	106.8	– 109.2	16	35	25	98	130	150
110.0	108.8	– 111.4	16	35	25	98	130	150
114.3	113.0	– 115.5	16	35	25	98	135	155
122.0	120.8	– 123.2	16	32	35	113	145	165
129.0	127.6	– 131.1	16	32	35	113	155	185
133.0	131.5	– 134.4	16	32	35	113	160	190
139.7	138.1	– 141.6	16	32	35	113	165	195
141.3	139.6	– 142.8	16	32	35	113	170	200
154.0	152.3	– 156.1	16	32	35	113	180	210
159.0	157.3	– 160.7	16	32	35	113	185	215
168.3	166.5	– 170.1	16	32	35	113	195	225

1) PN (nominal pressure) is the max. admissible working pressure in shipbuilding, based on a safety factor of ≥ 4 .

2) WP is the max. working pressure in industrial applications, based on a safety factor as per NORMA specification.

● FLEX 3

The pipe coupling with extra wide band



- 1 Double-lip sealing system
- 2 Standard strip insert
- 3 Heavy duty lock bars

ADVANTAGES Easy and quick to assembly.
Pipe end distance up to 65 mm possible.
Compensation of misalignment, angular deflection up to 4° possible.

TECHNICAL DATA

Sizes: from 326,0 mm to 2032,0 mm
Working pressure: 16,5 bar - 1,5 bar
Solid trunnions
2 closure units from size > 800,0 mm
Material: AISI 316 Ti
EPDM: Sizes > 180,0 mm : - 20 °C up to + 80 °C
NBR: from - 20 °C up to + 80 °C

DIMENSIONS

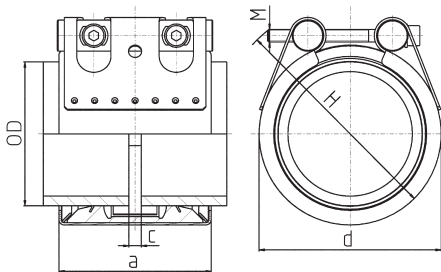

FEATURES

- FLEX 3, featuring an extra wide band, is a non-axial restraint coupling used to connect metal and or plastic pipes quickly and safely.

OD (mm)	Clamping range		WP ¹⁾  (bar)	C _{max} (mm)	Dimensions		
	ODmin (mm)	– ODmax (mm)			a (mm)	d clamped approx. (mm)	H approx. (mm)
326.0	322.0	– 329.0	16.5	65	211	365	405
355.6	352.0	– 359.0	15.5	65	211	395	435
406.4	402.0	– 410.0	13.5	65	211	445	485
429.0	426.0	– 431.0	12.5	65	211	465	505
442.0	439.0	– 444.0	12.0	65	211	480	520
457.2	454.0	– 459.0	12.0	65	211	495	535
508.0	505.0	– 510.0	10.5	65	211	545	585
531.0	528.0	– 534.0	10.0	65	211	570	610
558.8	556.0	– 562.0	9.5	65	211	595	635
609.6	606.0	– 613.0	9.0	65	211	645	685
634.0	631.0	– 637.0	8.5	65	211	670	710
711.2	707.0	– 715.0	7.5	65	211	750	790
762.0	758.0	– 766.0	7.0	65	211	800	840
812.8	808.0	– 817.0	6.5	65	211	850	890
914.4	909.0	– 919.0	6.0	65	211	950	990
1016.0	1013.0	– 1019.0	5.0	65	211	1055	1095
1117.5	1114.0	– 1120.0	4.5	65	211	1155	1195
1219.2	1216.0	– 1222.0	4.0	65	211	1255	1295
1320.8	1314.0	– 1328.0	3.0	65	211	1360	1400
1422.4	1415.0	– 1430.0	3.0	65	211	1460	1500
1524.0	1516.0	– 1532.0	2.5	65	211	1560	1600
1625.6	1617.0	– 1634.0	2.5	65	211	1665	1705
1727.2	1718.0	– 1736.0	2.0	65	211	1765	1805
1828.8	1819.0	– 1838.0	2.0	65	211	1865	1905
1930.4	1920.0	– 1940.0	2.0	65	211	1970	2010
2032.0	2021.0	– 2042.0	1.5	65	211	2070	2110

1) WP is the max working pressure in industrial applications, based on a safety factor as per NORMA specification.
For the pipes to be joined the max. difference in diameter must not exceed 5 mm.
All pipe couplings ≥ 800 mm are in 2 parts.

● REP E

The repair coupling

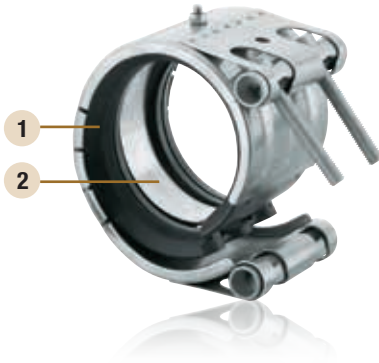

- 1 Double-lip sealing system
- 2 Standard strip insert

ADVANTAGES Ensure a reliable safety leakage free connection. Enable easy, quickly and safety repair without dismantling the pipes
Easy to install without special tools.

TECHNICAL DATA

Sizes: from 35,0 mm to 1219,1 mm

Working pressure: from 60,0 bar to 4,0 bar

Material: AISI 316 Ti

EPDM:

Sizes from 26,9 mm up to 168,3 mm: - 30 °C up to + 125 °C.

Sizes > 180,0mm: - 20 °C up to + 80 °C

NBR : from - 20 °C up to + 80 °C

DIMENSIONS

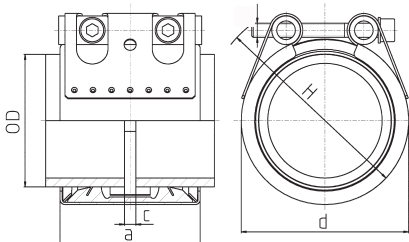

FEATURES

REP E couplings are none axial restraint couplings to stop easily leakage at pipes. They are used to connect and / or seal damaged metal and plastic pipes.

OD	Clamping range		WP ¹⁾ 	C _{max}	Dimensions		
	ODmin	– ODmax			a	d	H
(mm)	(mm)	(mm)	(bar)	(mm)	(mm)	approx. (mm)	clamped approx. (mm)
35.0	34.5	– 35.6	60	8	63	55	75
38.0	37.5	– 38.6	60	8	63	60	80
42.4	41.7	– 43.0	50	8	63	65	85
44.5	44.0	– 45.1	50	8	63	65	85
48.3	47.6	– 50.5	50	8	63	70	90
54.0	53.3	– 54.6	50	17	78	75	95
57.0	56.3	– 57.7	50	17	78	80	100
60.3	59.5	– 61.0	40	17	78	85	105
63.0	62.2	– 63.9	40	17	78	85	105
70.0	69.0	– 71.0	40	25	98	90	110
73.0	72.1	– 73.8	40	25	98	95	115
76.1	75.2	– 77.0	35	25	98	100	120
78.0	77.1	– 78.9	35	25	98	100	120
80.0	79.0	– 80.8	35	25	98	100	120
84.0	83.0	– 85.0	35	25	98	105	125
88.9	87.0	– 89.9	35	25	98	110	130
98.0	96.9	– 99.0	35	25	98	120	140
101.6	100.4	– 102.8	35	25	98	125	145
104.0	102.8	– 106.1	35	25	98	125	145
108.0	106.8	– 109.2	35	25	98	130	150
110.0	108.8	– 111.4	35	25	98	130	150
114.3	113.0	– 115.5	35	25	98	135	155
122.0	120.8	– 123.2	32	35	113	145	165
129.0	127.6	– 131.1	32	35	113	155	185
133.0	131.5	– 134.4	32	35	113	160	190
139.7	138.1	– 141.6	32	35	113	165	195
141.3	139.6	– 142.8	32	35	113	170	200
154.0	152.3	– 156.1	32	35	113	180	210
159.0	157.3	– 160.7	32	35	113	185	215
168.3	166.5	– 170.1	32	35	113	195	225
180.0	178.0	– 182.0	30.0	35	139	210	240
193.7	192.0	– 196.0	28.0	35	139	225	255
206.0	202.0	– 208.0	26.5	35	139	240	270
219.1	216.0	– 221.0	23.0	35	139	250	280
225.0	222.0	– 227.0	23.0	35	139	255	285
229.9	228.0	– 232.0	23.0	35	139	260	290
244.5	242.0	– 247.0	22.0	35	139	275	305
254.0	250.0	– 256.0	21.0	35	139	285	315
267.0	264.0	– 269.0	20.0	35	139	300	330
273.0	270.0	– 275.0	20.0	35	139	305	335
306.0	302.0	– 308.0	17.5	35	139	340	370
323.9	320.0	– 327.0	17.5	35	139	355	385
326.0	322.0	– 329.0	16.5	35	139	360	390
355.6	352.0	– 359.0	15.0	35	139	390	420
406.4	402.0	– 410.0	14.0	35	139	440	470
429.0	426.0	– 431.0	13.0	35	139	460	490
442.0	439.0	– 444.0	13.0	35	139	475	505
457.2	454.0	– 459.0	12.0	35	139	490	520
508.0	505.0	– 510.0	11.0	35	139	540	570
531.0	528.0	– 534.0	10.5	35	139	565	595
558.8	556.0	– 562.0	10.0	35	139	590	620
609.6	606.0	– 613.0	9.0	35	139	640	670
634.0	631.0	– 637.0	8.0	35	139	665	695
711.2	707.0	– 715.0	7.0	35	139	745	775
762.0	758.0	– 766.0	7.0	35	139	795	825
812.8	808.0	– 817.0	6.5	35	139	845	875
914.4	909.0	– 919.0	5.5	35	139	945	975
1016.0	1013.0	– 1019.0	5.0	35	139	1050	1080
1117.5	1114.0	– 1120.0	4.5	35	139	1150	1180
1219.2	1216.0	– 1222.0	4.0	35	139	1250	1280

1) WP is the max working pressure in industrial applications, based on a safety factor as per NORMA specification.
 Sizes > 1219.2 mm on request.





For axial restraint connections



Axial restraint pipe couplings type Grip/Grip E, Plast Grip and Combi Grip are used to join strong axial restraint connections. Only metal pipes, plastic pipes and also in the combination one side plastic other side metal pipes could be connection easy without tools with restraint connectors.

The anchoring systems, with conically stamped teeth or flat rows of teeth engage into the pipe surface without damaging the pipe material.

Owing to the special design the couplings can withstand even high vibration loads.

● GRIP/GRIP E

The strong pipe coupling

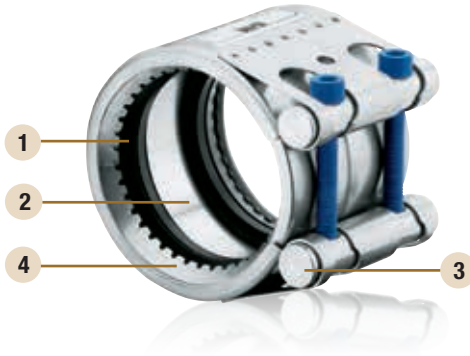

- 1 Double-lip sealing system
- 2 Standard strip insert
- 3 Heavy duty lock bars
- 4 Anchoring ring with conically stamped teeth

ADVANTAGES Progressive locking effect ensure a trouble and maintenance free connection. Reusable. Shock resistant. Space saving connector. Withstand high vibration loads.

TECHNICAL DATA

Sizes: 26,9 mm- 711,2 mm

Working pressure: 70,0 bar - 2,5 bar

Material: AISI 304, AISI 316 Ti

EPDM:

Sizes from 26,9 mm up to 168,3 mm: - 30 °C up to + 125 °C.

Sizes > 180,0 mm: from - 20 °C up to + 80 °C

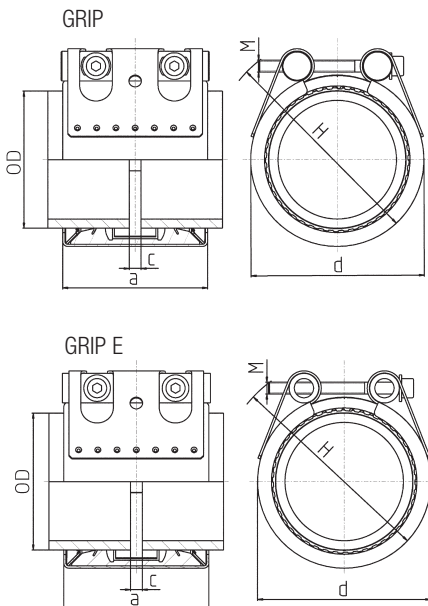

NBR: from - 20 °C up to + 80 °C

DIMENSIONS





FEATURES

GRIP/GRIP E axial restraint pipe couplings are used to connect metal pipes. The anchoring ring with conically stamped teeth indents into the pipe surface (steel, stainless steel or cast iron) and provides safe and strong axial restraint.

OD (mm)	Clamping range (mm)		PN ¹⁾  (bar)	WP ²⁾  (bar)	C _{max} (mm)	Dimensions			
	ODmin	ODmax				a (mm)	d clamped approx. (mm)		H approx. (mm)
26.9	26.4	– 27.5	16	70	3	67	50		70
28.0	27.5	– 28.5	16	70	3	67	50		70
30.0	29.5	– 30.6	16	70	3	67	50		70
33.7	33.0	– 34.3	16	60	3	67	55		75
35.0	34.5	– 35.6	16	60	8	63	55		75
38.0	37.5	– 38.6	16	60	8	63	60		80
42.4	41.7	– 43.0	16	50	8	63	65		85
44.5	44.0	– 45.1	16	50	8	63	65		85
48.3	47.6	– 50.5	16	50	8	63	70		90
54.0	53.3	– 54.6	16	50	17	78	75		95
57.0	56.3	– 57.7	16	50	17	78	80		100
60.3	59.5	– 61.0	16	40	17	78	85		105
63.0	62.2	– 63.9	16	40	17	78	85		105
70.0	69.0	– 71.0	16	40	25	98	90		110
73.0	72.1	– 73.8	16	40	25	98	95		115
76.1	75.2	– 77.0	16	35	25	98	100		120
78.0	77.1	– 78.9	16	35	25	98	100		120
80.0	79.0	– 80.8	16	35	25	98	100		120
84.0	83.0	– 85.0	16	35	25	98	105		125
88.9	87.0	– 89.9	16	35	25	98	110		130
101.6	100.4	– 102.8	16	35	25	98	125		145
104.0	102.8	– 106.1	16	35	25	98	125		145
110.0	108.8	– 111.4	16	35	25	98	130		150
114.3	113.0	– 115.5	16	35	25	98	135		155
122.0	120.8	– 123.2	16	32	35	115	145		165
129.0	127.6	– 131.1	16	32	35	115	155		185
133.0	131.5	– 134.4	16	32	35	115	160		190
139.7	138.1	– 141.6	16	32	35	115	165		195
141.3	139.6	– 142.8	16	32	35	115	170		200
154.0	152.3	– 156.1	16	32	35	115	180		210
159.0	157.3	– 160.7	16	32	35	115	185		215
168.3	166.5	– 170.1	16	32	35	115	195		225

¹⁾ **PN** (nominal pressure) is the max. admissible working pressure in shipbuilding, based on a safety factor of ≥ 4 .

²⁾ **WP** is the max. working pressure in industrial applications, based on a safety factor as per NORMA specification.

OD	Clamping range		MAWP ³⁾		WP ²⁾		C _{max}	Dimensions				
(mm)	ODmin – ODmax (mm)		 (bar)		 (bar)		(mm)	a (mm)		d clamped approx. (mm)		H approx. (mm)
			GRIP	GRIP E	GRIP	GRIP E		GRIP	GRIP E			
193.7	192.0	– 196.0	16.0	10.0	32.0	20.0	35	142	141	225	255	
206.0	202.0	– 208.0	16.0	10.0	32.0	20.0	35	142	141	240	270	
219.1	216.0	– 221.0	16.0	10.0	32.0	20.0	35	142	141	250	280	
225.0	222.0	– 227.0	13.0	10.0	26.5	16.0	35	142	140	255	285	
229.9	228.0	– 232.0	13.0	5.5	26.0	16.0	35	142	140	260	290	
244.5	242.0	– 247.0	12.0	5.5	24.5	15.0	35	142	140	275	305	
254.0	250.0	– 256.0	11.5	5.5	22.5	14.0	35	142	140	285	315	
267.0	264.0	– 269.0	11.0	5.5	22.5	13.5	35	142	140	300	330	
273.0	270.0	– 275.0	11.0	5.5	22.0	13.0	35	142	140	305	335	
306.0	302.0	– 308.0	9.5	5.5	19.5	10.5	35	142	140	340	370	
323.9	320.0	– 327.0	6.5	3.0	13.0	9.5	35	142	140	355	385	
326.0	322.0	– 329.0	6.5	3.0	13.0	9.5	35	142	140	360	390	
355.6	352.0	– 359.0	6.0	2.7	12.0	8.5	35	142	140	390	420	
406.4	402.0	– 410.0	4.5	2.5	9.0	7.0	35	142	140	440	470	
429.0	426.0	– 431.0	4.0	2.5	8.5	6.5	35	142	140	460	490	
442.0	439.0	– 444.0	4.0	2.5	8.0	6.5	35	142	140	475	505	
457.2	454.0	– 459.0	4.0	2.5	8.0	6.0	35	142	140	490	520	
508.0	505.0	– 510.0	2.5	2.0	5.0	4.0	35	142	140	540	570	
531.0	528.0	– 534.0	2.5	1.5	5.0	4.0	35	142	140	565	595	
558.8	556.0	– 562.0	2.0	1.5	4.5	3.5	35	142	140	590	620	
609.6	606.0	– 613.0	1.5	1.0	3.0	2.0	35	142	140	640	670	
634.0	631.0	– 637.0	1.5	---	3.0	---	35	142	---	665	695	
711.2	707.0	– 715.0	1.5	---	2.5	---	35	142	---	745	775	

¹⁾ **MAWP** (maximum allowable working pressure) is the max. admissible working pressure in shipbuilding, based on a safety factor of ≥ 4 .

²⁾ **WP** is the max working pressure in industrial applications, based on a safety factor as per NORMA specification.

For the pipes to be joined the max. difference in diameter must not exceed 5 mm.

● GRIP/GRIP E-FP

The fire resistant Coupling

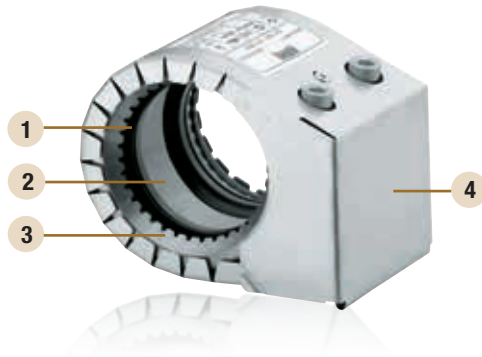

- 1 Double-lip sealing system
- 2 Standard strip insert
- 3 Conically stamped anchoring ring
- 4 Flame protection housing

ADVANTAGES Dampens absorbing vibrations, pressure surges. Weight saving. Tension free. Ready to install.

TECHNICAL DATA

Sizes: 40,0 mm - 406,0 mm

Working pressure: 16,0 - 6,0 bar

Material: AISI 304, AISI 316 Ti

EPDM:

Sizes from 26,9 mm up to 168,3 mm: - 30 °C up to + 125 °C.

Sizes > 180,0 mm: from - 20 °C up to + 80 °C

NBR: from - 20 °C up to + 80 °C

FEATURES

The fire resistant coupling

GRIP E-FP pipe couplings with integrated flame protection are used with applications in the marine sector (civil and military) as well in sprinkler systems. For this purpose the GRIP E type has been equipped with an additional housing made from stainless steel plus a fire-resistant lining. The pipe coupling meets the newest VDS directives, IACS P2.11 and ISO 19921/22. Pressures and dimensions on request.

● GRIP/GRIP E-FP

RFP for shipbuilding applications

Metal housing made
from AISI 316 Ti

Environment friendly
No use of chemicals

Shoulders of the
coupling are flame
protected

Double-locked safeguards
prevent from dismantling

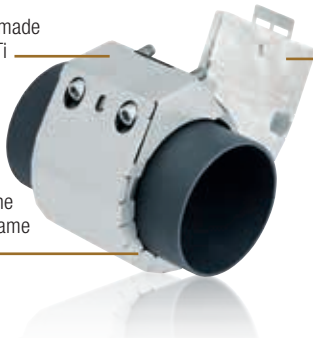

ADVANTAGES

- Retrofittable
- Easy assembly without tooling
- Low weight
- Meets update IACS requirements
- No chemicals in flame protection mat
- High flexibility
- Clear identification whether coupling is flame protected or not
- Mechanical stress resistant
- Less warehouse costs

TECHNICAL DATA

Sizes from 26,9 mm up to 323,9 mm

FEATURES

RFP for shipbuilding applications

RFP is a retrofittable flame protection housing that has been specially designed for use with all pipe couplings FLEX, GRIP, REP E. Its low weight and straightforward design allow quick, easy assembly without any tools and the built-in flame resistant mineral fibre mat provides a premium level of flame protection. The new Retrofit Flame Protection (RFP) housing has been extensively tested and is approved by Germanischer Lloyd, Bureau Veritas, American Bureau of Shipping, Det Norske Veritas, Korean Register of Shipping, Russian Maritime Register of Shipping, Polski Rejestr Statkon and Nippon Kaijii Kyokai/Class NK.



● PLAST GRIP / PLAST GRIP E

The coupling for plastic pipes

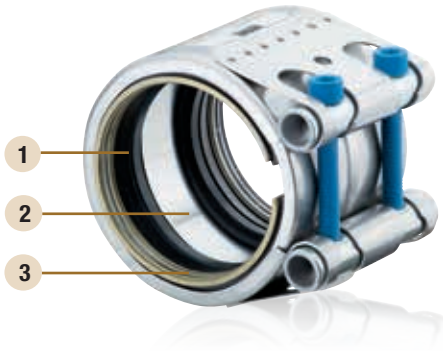

- 1 Double-lip sealing system*
- 2 Standard strip insert*
- 3 Anchoring ring

ADVANTAGES

- No welding
- No adjustments of the pipes/connectors necessary
- Useable for weak plastic pipes, PP, PE

TECHNICAL DATA

Sizes: 40,0 mm - 406,0 mm

Working pressure: 16,0 - 6,0 bar

Material: AISI 304, AISI 316 Ti

EPDM:

Sizes from 26,9 mm up to 168,3 mm - 30 °C up to + 125 °C.

Sizes > 180,0 mm: - 20 °C up to + 80 °C

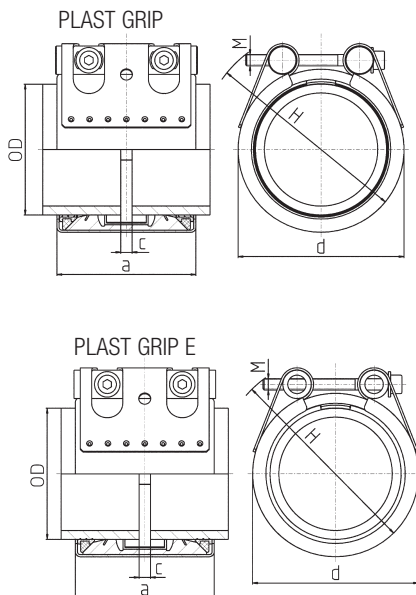

NBR: - 20 °C up to + 80 °C

DIMENSIONS



FEATURES

PLAST GRIP/ PLAST GRIP E axial restraint pipe couplings are used to connect plastic pipes. The specially designed anchoring ring featuring flat rows of the teeth engages into the pipe surface without damaging the plastic material. The force applied is distributed evenly across the pipe surface.

OD	Clamping range			PN ¹⁾	WP ²⁾	C _{max}	Dimensions		
(mm)	ODmin – ODmax Plastics (mm)			 (bar)	 (bar)	(mm)	a (mm)	d clamped approx. (mm)	H approx. (mm)
40.0	39.0	–	40.5	10	16	8	62	60	80
42.4	41.7	–	43.0	10	16	8	62	65	85
48.3	47.6	–	49.5	10	16	8	62	70	90
50.0	49.0	–	50.5	10	16	8	62	70	90
60.3	59.5	–	61.0	10	16	17	78	85	105
63.0	62.0	–	63.5	10	16	17	78	85	105
73.0	72.0	–	74.0	10	16	25	98	95	115
75.0	74.0	–	76.0	10	16	25	98	100	120
76.0	75.0	–	77.0	10	16	25	98	100	120
88.9	88.0	–	90.0	10	16	25	98	110	130
90.0	89.0	–	91.0	10	16	25	98	110	130
101.6	100.4	–	102.8	10	16	25	98	125	145
110.0	109.0	–	111.0	10	16	25	98	130	150
114.3	113.0	–	115.5	10	16	25	98	135	155
140.0	139.0	–	141.0	10	16	35	115	160	180
141.3	138.1	–	141.6	10	16	35	115	165	185
160.0	159.0	–	162.0	10	16	35	115	180	200
168.3	166.5	–	170.1	10	16	35	115	190	210
180.0	178.0	–	182.0	-	16	35	142	210	240
200.0	198.0	–	202.0	-	16	35	142	230	260
219.1	217.0	–	222.0	-	16	35	142	250	280
225.0	222.0	–	227.0	-	10	35	142	255	285
250.0	247.0	–	253.0	-	10	35	142	280	310
273.0	271.0	–	276.0	-	10	35	142	305	335
280.0	277.0	–	283.0	-	10	35	142	310	340
315.0	311.0	–	318.0	-	10	35	142	345	375
323.9	320.0	–	327.0	-	6	35	142	355	385
355.0	352.0	–	359.0	-	6	35	142	385	415
400.0	396.0	–	404.0	-	6	35	142	430	460
406.4	402.0	–	410.0	-	6	35	142	440	470

¹⁾ **PN** (nominal pressure) is the max. admissible working pressure in shipbuilding, based on a safety factor of ≥ 4 .

²⁾ **WP** is the max. working pressure in industrial applications, based on a safety factor as per NORMA specification.

³⁾ For sizes bigger than 168.3 mm only in version with solid trunnions

● COMBI GRIP / COMBI GRIP E

The combination pipe coupling

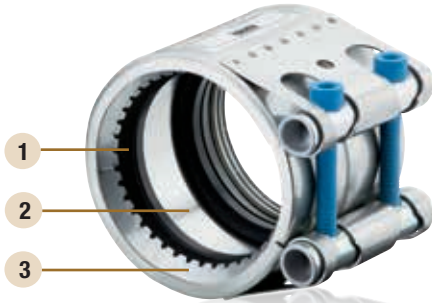

- 1 Double-lip sealing system*
- 2 Standard strip insert*
- 3 Anchoring ring

ADVANTAGES

- Corrosion resistant
- No welding
- No special tools necessary
- Installation and working in everything kind of weather (heat and cold)
- Reusable.

TECHNICAL DATA

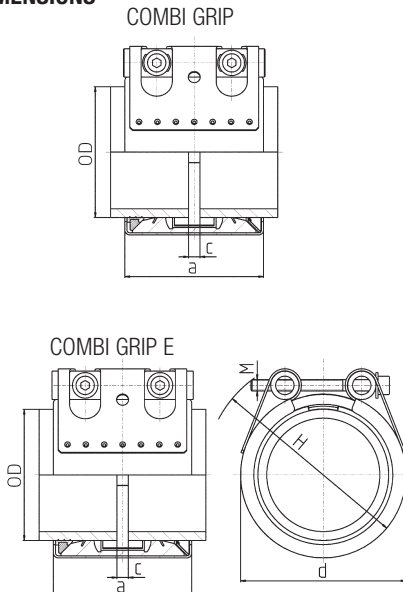

Sizes: from 38/40,0 mm to 406,0/406,0 mm
 Working pressure: 16,0 - 6,0 bar
 Material: AISI 304, AISI 316 Ti
 EPDM:
 Sizes from 26,9 mm up to 168,3 mm: - 30 °C up to + 125 °C
 Sizes > 180,0 mm: - 20 °C up to + 80 °C
 NBR: from - 20 °C up to + 80 °C

DIMENSIONS



FEATURES

GRIP/COMBI GRIP E axial restraint pipe couplings are used to connect plastic pipes with metal pipes. For the plastic pipe the coupling features on one side a special anchoring ring with rows of flat teeth which are pressed into the pipe surface without damaging the material. At the same time the force applied is distributed evenly across the pipe surface. For the metal pipe the coupling features on the other side an anchoring ring with conically stamped teeth which grip into the pipe surface. Due to the special design of the anchoring ring the coupling can withstand even high vibration loads.

OD	Clamping range		Clamping range		PN ¹⁾	WP ²⁾	C _{max}	Dimensions		
	ODmin – ODmax Plastics	ODmin – ODmax Metal						a	d clamped approx.	H approx.
(mm)	(mm)	(mm)			(bar)	(bar)	(mm)			
40.0/38.0	39.0 – 40.5	37.5 – 38.6	10	16	8	62	60	80		
40.0/42.4	39.0 – 40.5	41.7 – 43.0	10	16	8	62	65	85		
42.4/42.4	41.7 – 43.0	41.7 – 43.0	10	16	8	62	65	85		
48.3/48.3	47.6 – 50.5	47.6 – 50.5	10	16	8	62	70	90		
50.0/48.3	49.0 – 50.5	47.6 – 50.5	10	16	8	62	70	90		
60.3/60.3	59.5 – 61.0	59.5 – 61.0	10	16	17	78	85	105		
63.0/60.3	62.0 – 63.5	59.5 – 61.0	10	16	17	78	85	105		
73.0/73.0	72.0 – 74.0	72.1 – 73.8	10	16	25	98	95	115		
75.0/76.1	74.0 – 76.0	75.2 – 77.0	10	16	25	98	100	120		
88.9/88.9	88.0 – 90.0	87.0 – 89.9	10	16	25	98	110	130		
90.0/88.9	89.0 – 91.0	87.0 – 89.9	10	16	25	98	110	130		
101.6/101.6	100.4 – 102.8	100.4 – 102.8	10	16	25	98	125	145		
110.0/108.0	109.0 – 111.0	106.8 – 109.2	10	16	25	98	130	150		
110.0/114.3	109.0 – 111.0	113.0 – 115.5	10	16	25	98	135	155		
114.3/114.3	113.0 – 115.5	113.0 – 115.5	10	16	25	98	135	155		
125.0/129.0	124.0 – 126.0	127.6 – 131.1	10	16	35	115	150	170		
140.0/139.7	139.0 – 141.0	138.1 – 141.6	10	16	35	115	160	180		
141.3/141.3	138.1 – 141.6	139.6 – 142.8	10	16	35	115	165	185		
160.0/159.0	159.0 – 162.0	157.3 – 160.7	10	16	35	115	180	200		
168.3/168.3	166.5 – 170.1	166.5 – 170.1	10	16	35	115	190	210		
200.0/204.0	198.0 – 202.0	202.0 – 206.0	-	16	35	142	235	265		
219.1/219.1	217.0 – 222.0	216.0 – 221.0	-	16	35	142	250	280		
225.0/219.1	222.0 – 227.0	216.0 – 221.0	-	10	35	142	255	285		
225.0/222.0	222.0 – 227.0	220.0 – 224.0	-	10	35	142	255	285		
250.0/254.0	247.0 – 253.0	250.0 – 256.0	-	10	35	142	285	315		
273.0/273.0	271.0 – 276.0	270.0 – 275.0	-	10	35	142	305	335		
280.0/273.0	277.0 – 283.0	270.0 – 275.0	-	10	35	142	310	340		
323.9/323.9	320.0 – 327.0	320.0 – 327.0	-	6	35	142	355	385		
355.0/355.6	351.0 – 359.0	352.0 – 359.0	-	6	35	142	390	420		
400.0/406.4	396.0 – 404.0	402.0 – 410.0	-	6	35	142	440	470		
406.0/406.4	402.0 – 410.0	402.0 – 410.0	-	6	35	142	440	470		

¹⁾ PN (nominal pressure) is the max. admissible working pressure in shipbuilding, based on a safety factor of ≥ 4 .

²⁾ WP is the max. working pressure in industrial applications, based on a safety factor as per NORMA specification.

³⁾ For sizes bigger than 168.3 mm only in version with solid trunnions

ACCESSORIES

● SUPPORT SLEEVE



To be used with FGR PLAST GRIP/PLAST GRIP E, COMBI GRIP/COMBI GRIP E in W5 (1.4571) material. For copper and CuNiFe pipes an optional support sleeve made from brass is available on request.

Ø OD mm	S-3.2 (SDR 7.5)	S-4 (SDR 9)	S-5 (SDR 11)	S-6.3 (SDR 13.6)	VPE
	Ø di* mm	Ø di* mm	Ø di* mm	Ø di* mm	
40	29	31	32.6	34	10
50	36	38.8	40.8	42.6	10
63	45.6	48.8	51.4	53.6	10
75	54.4	58.2	61.4	64	10
90	65.4	69.5	73.6	76.8	10
110	79.5	85.4	90	93.8	10
125	91	97	102.2	106.6	5
140	102.2	108.6	114.6	119.4	5
160	116.2	124.2	130.8	136.4	5

Ø OD mm	S-8 (SDR 17)	S-10 (SDR 21)	S-12.5 (SDR 26)	S-16 (SDR 33)	VPE
	Ø di* mm	Ø di* mm	Ø di* mm	Ø di* mm	
40	35.2	-	36	-	10
50	44	45.6	46	-	10
63	55.4	57	58.2	59	10
75	66	67.8	69.5	70.4	10
90	79.5	81.4	83	84.4	10
110	96.8	99.4	101.6	103.2	10
125	110.2	113	115.4	117.2	5
140	123.4	126.6	129.2	131.4	5
160	141	144.6	147.6	150.2	5

* Additional diameters on request.

● FITTING PLIERS / FITTING DOUBLE PLIERS



For FGR Rep E

Ø OD mm	Text for ordering
38–168.3 mm	Fitting pliers for REP E
180–1200 mm	Fitting double pliers for REP E





DCS

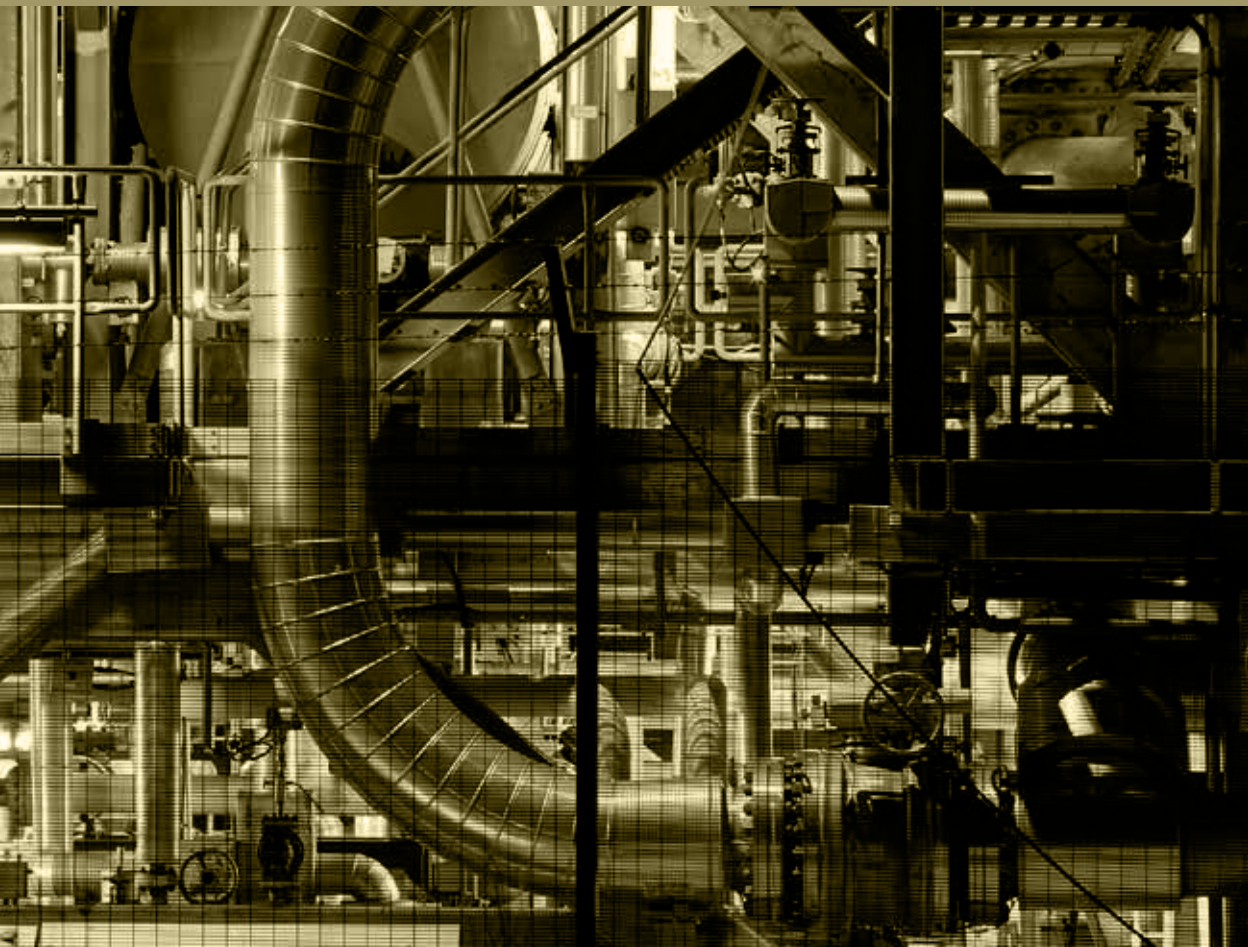

OUR SOLUTION FOR **DRAINAGE CONNECTING – DCS**

The original product for high quality and reliability.

The complete DCS range has been proven a million times when used to achieve both a reliable and economic connection of plain ended drainage pipes.

Inside buildings, in underground car parks, buried in soil, in purification plants and for drainage systems in bridges, DCS is the ideal connecting solution.

A large number of well-known companies have been using our know-how in the development and manufacture of pipe connections for many years. Thus behind many successful brands enjoying a well established reputation you can find the certified quality and the reliability of NORMA® connections.

Since the materials for our products are carefully chosen to match their applications and operating conditions, we can assure you that they function safely for a long time – as you would expect from a modern piping system.



CERTIFICATES, LIABILITY, MEMBERSHIPS

Certificates

Materialprüfungsamt Nordrhein-Westfalen
(MPA NRW)

Liability

Product liability: In case of bodily injury and/or
material damage.

Memberships











IZEG – Informationszentrum Entwässerungstechnik Guss
GEG – Gütergemeinschaft Entwässerungstechnik Guss



Informationszentrum
Entwässerungstechnik Guss e.V.



PRODUCTS AND APPLICATIONS AT A GLANCE

TYPE	DN AND PRESSURE [bar]												SEAL TYPE	MATERIAL	APPLICATION			
	40	50	70	70/80	100	125	150	200	250	300	400	500			600	STANDARD	Buildings	Bridges
NON PULL-OUT RESISTANT CONNECTIONS																		
RAPID 	•	•	•	•	•	•	•	•	•					EPDM	W 2	•	-	-
RAPID 	•	•	•	•	•	•	•	•	•	•				EPDM	W 5	•	•	•
MSM RAPID 		•	•	•	•	•	•	•						EPDM	W 2	•	-	-
CV 		•	•	•	•	•	•	•	•	•				EPDM	W 2	•	-	-
CE 		•	•		•	•	•	•	•	•				EPDM	W 4	•	-	•*
SVE 		•		•	•	•	•	•						NR-SBR	PP-CO	-	-	•
PULL-OUT RESISTANT CONNECTIONS																		
UNIVERSAL Restraint Collar 		10	10	10	10	10	5	5	3	3				-	W 2	•	-	-
REKORD Restraint Collar 	10	10	10	10	10	5	5	3						-	W 1	•	-	-
KOMBI Restraint Collar 		10	10	10	10	5	5							-	W 1	•	-	-
CHANGEOVER CONNECTORS																		
FIX 		•	•	•	•	•								EPDM	-	•	-	-

•* Additional protection against corrosion * NBR on request
 Technical Changes reserved

MATERIALS AT A GLANCE

MATERIALS FOR COUPLINGS AND RESTRAINT COLLARS				
	COLLAR	CLAMPING UNIT	SCREWS, NUTS, BOLTS	SEALING SLEEVE
W1			Steel, protected surface	–
W2	AISI 430 Ti	AISI 304	Steel, protected surface	EPDM
W4	AISI 304	AISI 304	AISI 304	EPDM
W5	AISI 316 Ti	AISI 316 Ti	AISI 316	EPDM

	COLLAR	CLAMPING UNIT	SCREWS	SEALING SLEEVE
W2	AISI 304	Steel, protected surface	Steel, protected surface	EPDM
W5	AISI 316 Ti	AISI 316 Ti	AISI 316	EPDM





For non pull-out resistant connections



When it comes to the connection of non pull-out resistant pipes the building industry has been relying on DCS connections for decades.

DCS RAPID

The original Rapid with block tightening



- 1 Hexagonal socket bolt with washer
- 2 Square nut
- 3 Closure unit
- 4 Collar
- 5 Sealing sleeve

ADVANTAGE The visible torque control and the single-bolt closure provide for a fast and easy installation. For non pull-out resistant connections.

TECHNICAL DATA

Material	W2	W 5
Collar:	AISI 430 Ti	AISI 316 Ti
Clamping unit:	AISI 304/AISI 430 Ti	AISI 316 Ti
Bolts/Nuts:	Steel, surf. protected	AISI 316
Sealing sleeve:	EPDM	EPDM

DIMENSIONS

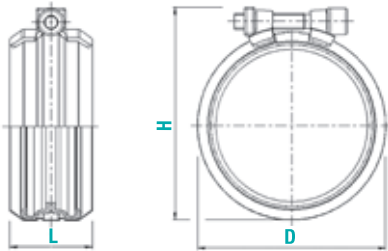

FEATURES

- Resisting axial pull-out forces up to max. 0.5 bar, DN 40–DN 200
- Resisting axial pull-out forces up to max 0.3 bar, DN 250–DN 300
- Defined locking torque without using a special tool
- Meeting the fire protection requirements

MAX. DIMENSIONS AFTER ASSEMBLY ~

DN	~D [mm]	~H [mm]	~L [mm]	P _{max} [bar]	Torque [Nm]	Bolt
40	53	64	41	0,5	Tight-Locking	M5
50	70	80	40	0,5	Tight-Locking	M 8
70	90	100	40	0,5	Tight-Locking	M 8
75S	87	97	40	0,5	Tight-Locking	M 8
80	95	105	40	0,5	Tight-Locking	M 8
100	125	135	46	0,5	Tight-Locking	M 8
125	147	162	55	0,5	Tight-Locking	M 8
150	172	187	55	0,5	Tight-Locking	M 8
200	227	244	70	0,5	Tight-Locking	M 10
250	293	306	96	0,3	Tight-Locking	M 10
300	345	360	96	0,3	Tight-Locking	M 10

● DCS RAPID MSM

The fast connection with quick release closure



- 1 Hexagonal socket bolt with washer
- 2 Square nut
- 3 Closure unit
- 4 Collar
- 5 Sealing sleeve

ADVANTAGE The RAPID MSM connection is easy-fitting and thus especially suitable for repair purposes.

TECHNICAL DATA

Material W2
 Collar: AISI 430 Ti
 Clamping unit: AISI 304 - AISI 430 Ti
 Bolts/Nuts: Steel, surf. protected
 Sealing sleeve: EPDM

DIMENSIONS

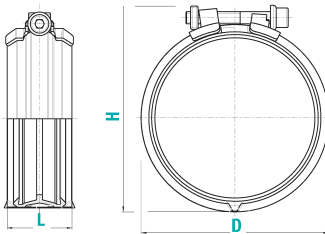

FEATURES

- Resisting axial pull-out forces up to max. 0.5 bar
- Defined locking torque without using a special tool
- Meeting the fire protection requirements

MAX. DIMENSIONS AFTER ASSEMBLY ~						
DN	~D [mm]	~H [mm]	~L [mm]	P _{max} [bar]	Torque [Nm]	Bolt
50	70	80	40	0,5	Tight-Locking	M 8
70	90	100	40	0,5	Tight-Locking	M 8
80	95	105	40	0,5	Tight-Locking	M 8
100	125	135	46	0,5	Tight-Locking	M 8
125	147	162	55	0,5	Tight-Locking	M 8
150	172	187	55	0,5	Tight-Locking	M 8
200	227	244	70	0,5	Tight-Locking	M 10

● DCS CV/CE

The proven standard collar



- 1 **CV:** Slotted hexagonal head bolts
DN 50 – DN 300: SW 10
CE: Hexagonal head bolts
DN 50, 70, 75/80: SW 10
DN 100 – DN 300: SW 13
- 2 Guide plate
- 3 Threaded plate
- 4 Collar
- 5 Sealing sleeve

ADVANTAGE The CV/CE collar has been proven in all kinds of standard drainage applications.

TECHNICAL DATA

Material	W2, Type CV	W 4 Type CE
Collar:	AISI 430 Ti	AISI 304
Clamping unit:	Steel, surf. protected	AISI 304
Bolts:	Steel, surf. protected	AISI 304
Sealing sleeve:	EPDM	EPDM

DIMENSIONS

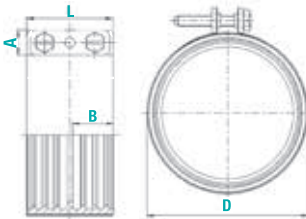

FEATURES

- Fast and easy installation
- Suitable for repair purposes

DN	A [mm]	B [mm]	~D [mm]	L [mm]	Torque [Nm]	Bolt
50	14	22,5	65	48	4 – 6	M 6
70	14	22,5	85	48	4 – 6	M 6
80	14	22,5	90	48	6 – 8	M 6
100	18	22,5	115	54	10 – 12	M 8
125	18	31	140	65	10 – 12	M 8
150	18	31	170	65	10 – 12	M 8
200*	18	37	220	78	15 – 20	M 8
250*	18	37	286	78	15 – 20	M 8
300*	18	37	338	78	15 – 20	M 8

* two pieces

● DCS SVE

The collar for buried drainage pipes



- 1 Housing
- 2 Sealing lips

ADVANTAGE Used to achieve the fast and easy connection of below ground drainage pipes – whilst also accommodating larger gaps between pipe ends. The DCS collar made from polypropylene with built-in sealing lips is the universal solution for many applications.

TECHNICAL DATA

Material

Housing: Polypropylene-CO
Seal: NR-SBR

DIMENSIONS

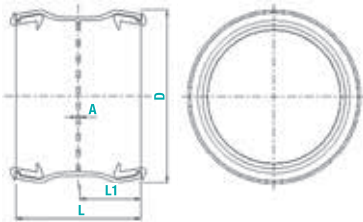

FEATURES

- Collar made from polypropylene with built-in sealing lips
- Compensates for larger gaps between pipe ends

DN	~D [mm]	L [mm]	L 1 [mm]	A [mm]
50	77	60	29	2
80	103,5	65,5	32	2
100	134	82	39,5	3
125	161	103	50	3
150	186	103	50	3
200	238	114	55,5	3





For pull-out resistant connections



The proven connection from our DCS range suitable for use with axial restraint pipes.

DCS UNIVERSAL Restraint Collar

The grip-type coupling resisting high tensile loads



- 1 Hexagonal socket bolts
- 2 Guide bolt
- 3 Threaded bolt
- 4 Housing
- 5 Grip ring insert

ADVANTAGE Combined with either DCS RAPID, DCS RAPID MSM or DCS CV/CE standard collars, our DCS Universal restraint collars ensure that the system can withstand even high tensile loads.

FEATURES

- Recommended for use in combination with types RAPID/RAPID MSM: up to max. 10 bar
- Recommended for use in combination with types CV/CE: up to max. 5 bar (DN 50 – DN 200); up to max. 3 bar (DN 250 – DN 300)

DIMENSIONS

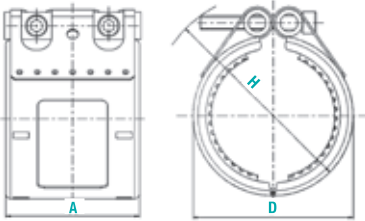

TECHNICAL DATA

Material	W2
Housing:	AISI 430 Ti
Closure unit:	Steel, surface protected
Grip ring:	AISI 301

DN	A [mm]	~D [mm]	~H [mm]	P _{max} [bar]		Torque [Nm]	Bolt
				RAPID/ RAPID MSM	CV/CE		
50	77	85	105	10	5	Tight-Locking	M 8
70	77	100	120	10	5	Tight-Locking	M 8
80	77	105	125	10	5	Tight-Locking	M 8
75S	77	100	120	10	5	Tight-Locking	M 8
100	97	130	150	10	5	Tight-Locking	M 10
125	97	165	195	10	5	Tight-Locking	M 10
150	97	185	215	5	5	Tight-Locking	M 10
200	113	240	270	5	5	Tight-Locking	M 12
250	139	305	335	3	4	Tight-Locking	M 12
300	139	400	490	3	3	Tight-Locking	M 12

● DCS REKORD Restraint Collar

The powerful add-on collar

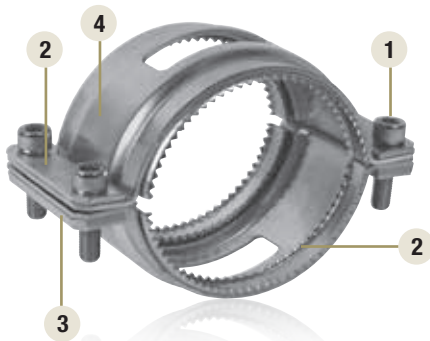

- 1 Hexagonal socket bolt with fine pitch thread
- 2 Guiding plate
- 3 Threaded plate
- 4 Housing
- 5 Grip ring insert (hardened)

ADVANTAGE Axial restraint safety clamp for use with pressurized pump lines in lifting systems as well as for rain water and sewage lines that are at risk of undergoing back pressures, but only in combination with the DCS RAPID standard collar.

TECHNICAL DATA

Material W1
 Housing: Steel, surface protected
 Closure unit: Steel, surface protected

DIMENSIONS

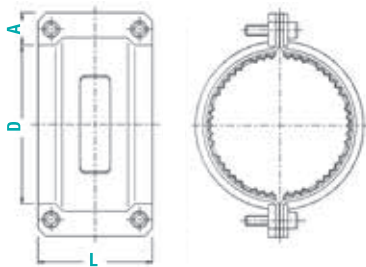

FEATURES

- Two parts (halves) with hardened grip ring inserts
- Strong guiding plates with threaded holes plus four hexagonal socket bolts with fine pitch thread

DN	A [mm]	~D [mm]	~L [mm]	P _{max} [bar]	Torque [Nm]	Bolt
40	21	65	66	up to 10	12 – 15	M 8
50	21	75	69	up to 10	12 – 15	M 8
70	21	95	69	up to 10	12 – 15	M 8
80	21	100	69	up to 10	12 – 15	M 8
100	25	135	87	up to 10	25 – 30	M 10
125	25	160	95	up to 5	30 – 35	M 10
150	25	185	95	up to 5	30 – 35	M 10
200	30	235	111	up to 3	60 – 65	M 12

DCS KOMBI Restraint Collar

The powerful add-on collar

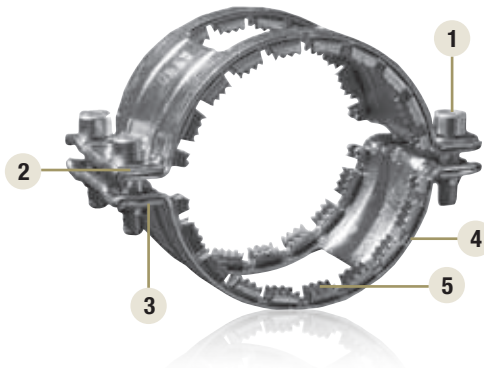

- 1 Hexagonal socket bolts
- 2 Guiding side
- 3 Threaded side
- 4 Housing
- 5 Grip ring insert

ADVANTAGE Axial restraint safety clamp for connecting rain water and sewage lines that are at risk of undergoing back pressures, used in combination with Rapid/Rapid MSM and CV or CE standard collars - diameters DN 50 up to DN 150.

FEATURES

- Axial restraint up to 10 bar

DIMENSIONS

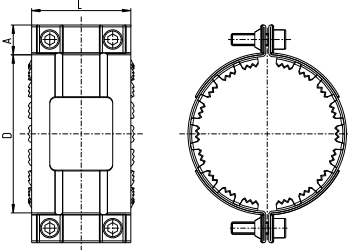

TECHNICAL DATA

Material	W1
Housing:	Steel, surface protected
Closure unit:	Steel, surface protected

DN	A [mm]	D [mm]	L [mm]	P _{max} [bar]	Torque [Nm]	Bolt
50	22	81	72	up to 10	18 – 20	M 8
70	22	102	72	up to 10	18 – 20	M 8
80	22	110	72	up to 10	18 – 20	M 8
100	22	136	82	up to 10	28 – 30	M 10
125	23,5	162	93	up to 5	28 – 30	M 10
150	23,5	186	93	up to 5	33 – 35	M 10

DN 200, DN 250, DN 300 on request



Changeover connectors



The flexible changeover connector for connecting pipes of various materials.

● DCS FIX

The Changeover connector with 2 lip seals



ADVANTAGE The connection of feed or suction lines to a pipe – either made of steel or plastics – is easily and safely achieved with the FIX connector.

FEATURES

- Easy handling
- Strong worm-drive hose clip

DIMENSIONS

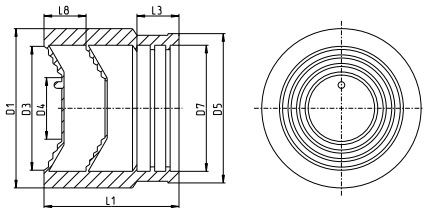

TECHNICAL DATA

Material

Connector: EPDM
Worm-drive hose clip band: 1.4016

DN	D1 [mm]	D3 [mm]	D4 [mm]	D5 [mm]	D7 [mm]	L1 [mm]	L3 [mm]	L8 [mm]
50	72	56	30	67,5	57	63	19	19
70	92	75	41	86,5	77	77	19	24
80	92	75	41	91	81	77	19	24
80	108	90	58	93	81	88	19	23
100	128	110	78	118	108	95	21	23
125	145	126	90	145	132	103	26	27

SURVEY OF SIZES

Dimensions of pipes and fittings to EN 877

DN	OUTSIDE DIAMETER (OD)		WALL THICKNESS	
	Nominal value	Tolerance	Nominal value	Minimum value
40	48	+2 -1	3,0	2,5
50	58	+2 -1	3,5	3,0
70	78	+2 -1	3,5	3,0
80	83	+2 -1	3,5	3,0
100	110	+2 -1	3,5	3,0
125	135	+2 -2	4,0	3,5
150	160	+2 -2	4,0	3,5
200	210	+2,5 -2,5	5,0	4,0
250	274	+2,5 -2,5	5,5	4,5
300	326	+2,5 -2,5	6,0	5,0
400	429	+2 -3	6,3	5,0
500	532	+2 -3,5	7,0	5,2
600	635	+2 -4	7,7	5,8

Dimensions in mm

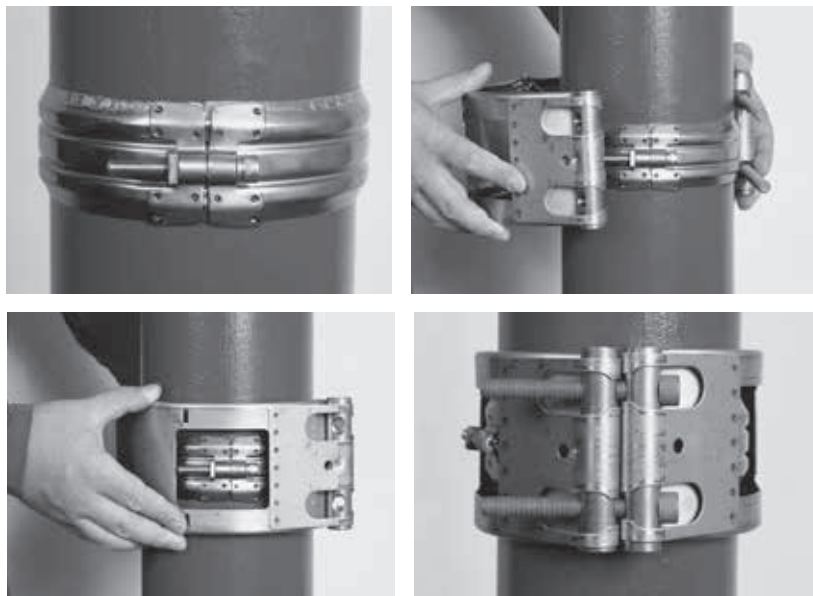





PSS



OUR SOLUTIONS FOR **SUPPORTING & FIXING**

The NORMA Pipe Support System (PSS) offers a large and reliable range of products, such as ISOPHONIC and NON-ISOPHONIC Pipe Clamps, Channels, Cantilevers, Fixing and Anchoring accessories, Cables Ties and Stainless Steel range.

Our PSS range brings solutions for instance for PIPES&TUBES or HVAC systems supporting. It can be used in several markets: Building, Sanitary and Water Management.

SPECIAL REQUEST

You can send us special request, such as Hot Dip Galvanization for Channels.

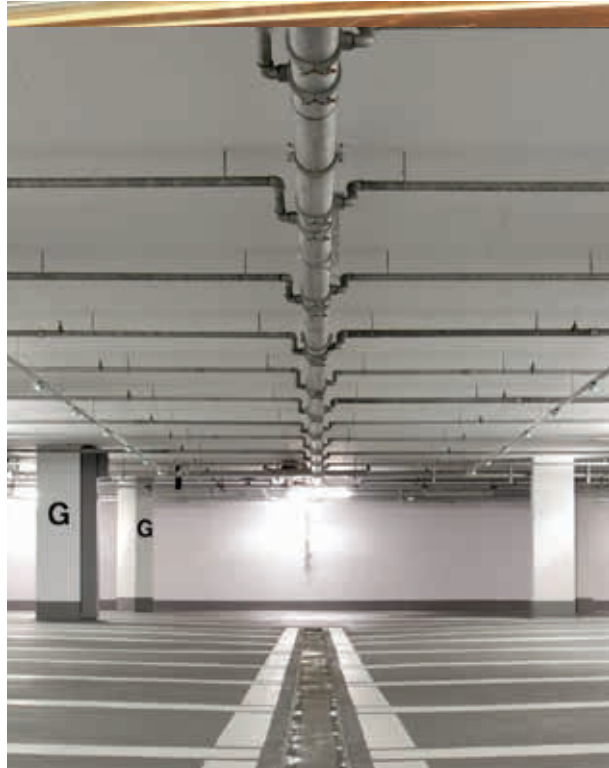







Non Isophonic Pipe Clamps



Usable as a fixed point, ideal for quick tube mounting. For installations without acoustic constraints. Simple pipe assembly for the building and the industry. Ideal attachment suspended under the ceiling or for channel.

● PIPE CLAMP M8/M10 WITH CAPTIVE SCREWS

For ventilation and aerualics



- 1 M8/M10 nut
- 2 2 unloss M6 screws with plastic washers
- 3 Band thickness: from 2 to 2,5 mm

DIMENSIONS

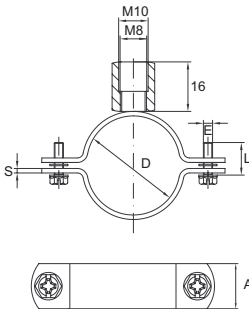

D mm	D mm	D "	A mm	S mm	E mm	L mm		N°	
18	15-19	3/8"	20	2,0	M6	15	2000	8474271018	50
22	20-25	1/2"	20	2,0	M6	15	2000	8474271022	50
28	26-30	3/4"	20	2,0	M6	15	2000	8474271028	50
35	32-36	1"	20	2,0	M6	15	2000	8474271035	50
40	38-43	1 1/4"	20	2,0	M6	20	2000	8474271040	25
48	47-51	1 1/2"	20	2,0	M6	20	2000	8474271048	25
54	53-56		20	2,0	M6	20	2000	8474271054	25
60	60-64	2"	20	2,0	M6	20	2000	8474271060	25
70	68-72		20	2,0	M6	20	2000	8474271070	25
75	75-80	2 1/2"	20	2,0	M6	20	2000	8474271075	25
83	81-86		20	2,0	M6	20	2000	8474271083	25
90	87-92	3"	20	2,0	M6	20	2000	8474271090	25
100	99-105	3 1/2"	20	2,0	M6	20	2000	8474271100	25
110	107-112		20	2,0	M6	20	2000	8474271110	25
115	113-118	4"	20	2,0	M6	20	2000	8474271115	25
125	125-130		20	2,0	M6	20	2000	8474271125	25
133	132-137		20	2,0	M6	20	2000	8474271133	25
140	138-142	5"	20	2,0	M6	26	2000	8474271140	25
150	148-152		20	2,0	M6	26	2000	8474271150	25
160	159-166	6"	20	2,0	M6	26	2000	8474271160	25
168	168-172		20	2,5	M6	26	2000	8474271168	25
180	179-184		20	2,5	M6	26	2000	8474271180	25
200	199-205		20	2,5	M6	26	2000	8474271200	25
220	215-220	8"	20	2,5	M6	26	2000	8474271220	25
224	223-228		20	2,5	M6	26	2000	8474271224	25
250	249-254		20	2,5	M6	26	2000	8474271250	25
300	299-304		20	2,5	M6	26	2000	8474271300	25
315	314-319		20	2,5	M6	26	2000	8474271315	25
355	354-359		20	2,5	M6	26	2000	8474271355	25
400	399-404		20	2,5	M6	26	2000	8474271400	25
450	449-454		20	2,5	M6	26	2000	8474271450	10
500	499-504		20	2,5	M6	26	2000	8474271500	10

ADVANTAGE plastic washers avoid the loss of side screws.

TECHNICAL DATA

Material: W1 (W5 available)
Isophonic version also available with EPDM

FEATURES

- Support up to max. 2000 N.

● HEAVY DUTY PIPE CLAMP M12

Heavy duty application: cast iron pipe



- 1 M12 nut
- 2 2 unloss screws M8 or M10
- 3 Band thickness: from 2 to 3 mm

DIMENSIONS

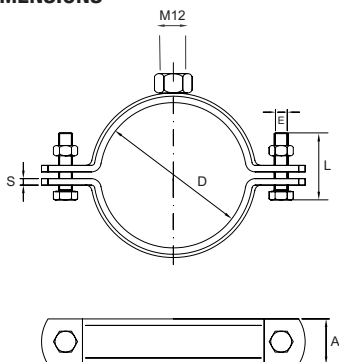



TECHNICAL DATA

Material: W1
 Temp: -40°C / +110°C
 Isophonic version available with EPDM

FEATURES

- Support up to max. 5000 N
- Side screws:
 - M8 for D22 to D110
 - M10 for D140 to D220

D mm	D mm	D "	A mm	S mm	E mm	L mm		N°	
22	20-24	1/2"	25	2	M8	25	3300	8474371022	50
28	25-30	3/4"	25	2	M8	25	3300	8474371028	50
35	32-38	1"	25	2	M8	25	3300	8474371035	50
40	39-46	1 1/4"	25	2	M8	25	3300	8474371040	50
48	48-53	1 1/2"	25	2	M8	25	3300	8474371048	50
60	59-66	2"	25	2	M8	25	3300	8474371060	40
75	74-80	2 1/2"	25	2	M8	25	3300	8474371075	30
90	87-94	3"	25	2	M8	25	3300	8474371090	30
110	108-116	4"	25	2,5	M8	25	4250	8474371110	30
140	135-143	5"	30	3	M10	30	4250	8474371140	10
160	162-168	6"	30	3	M10	30	5000	8474371160	10
220	206-220	8"	30	3	M10	30	5000	8474371220	10

● DRAIN PIPE CLAMP M8



- 1 Riveted M8 nut
- 2 2 unloss M6 screws with plastic washers
- 3 Band thickness: 1 mm

DIMENSIONS

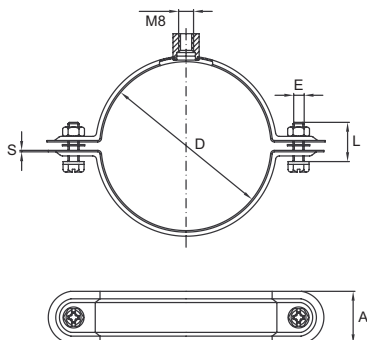



TECHNICAL DATA

Material: W1
Isophonic version also available with EPDM

FEATURES

- Support up to max. 1000 N

D mm	D mm	D "	A mm	S mm	E mm	L mm		N°	
75	75-80	2 1/2"	28	1	M6	20	1000	8471471075	50
80			28	1	M6	20	1000	8471471080	50
90	82-90	3"	28	1	M6	20	1000	8471471090	50
100			28	1	M6	20	1000	8471471100	50
110	106-112	3 1/2"	28	1	M6	20	1000	8471471110	25
125	124-130	4"	28	1	M6	20	1000	8471471125	25

● SPRINKLER PIPE CLAMP

AVAILABLE MID-2013



1 M8/M10 nut

DIMENSIONS

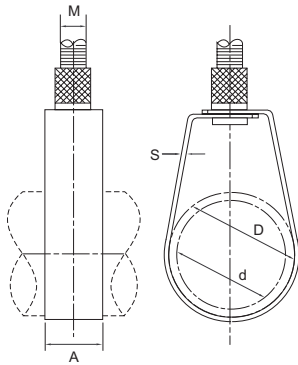

TECHNICAL DATA

Material: Electro BZP Steel

Suspended pipes, for fire fighting systems

D mm	d mm	D "	S mm	A mm	M mm	N°	
22	15	1/2"	1	22	M10	8473971022	100
28	20	3/4"	1	22	M10	8473971028	100
35	25	4"	1	22	M10	8473971035	100
40	32	1 1/4"	1,2	22	M10	8473971040	100
48	40	1 1/2"	1,2	22	M10	8473971048	100
60	50	2"	1,2	22	M10	8473971060	100
75	65	2 1/2"	1,2	22	M10	8473971075	100
90	80	3"	1,2	22	M10	8473971090	100
100	90	3 1/2"	1,2	22	M10	8473971010	100
115	100	4"	2	22	M10	8473971115	100
140	125	5"	2	32	M12	8473971140	50
160	150	6"	2	32	M12	8473971160	50
220	200	8"	2	40	M12	8473971220	25

● BRIDGE PIPE CLAMP



- 1 All in a piece
- 2 Hasp for easy installation

ADVANTAGE Moldable: easy twisting and allows to adapt itself to pipes of various diameters.

TECHNICAL DATA

Material: W1
Isophonic version also available with EPDM

DIMENSIONS

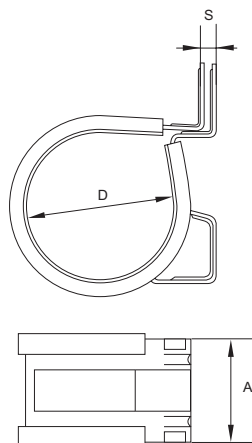

FEATURES

- Support up to max. 800 N

D mm	D "	A mm	S mm		N°	
12	1/4"	20	0,8	450	8474071012	50
15		20	0,8	450	8474071015	50
16	3/8"	20	0,8	450	8474071016	50
18		20	0,8	450	8474071018	50
20	1/2"	20	0,8	450	8474071020	50
22		20	0,8	450	8474071022	50
25		20	0,8	450	8474071025	50
28	3/4"	20	1,0	450	8474071028	50
32	1"	20	1,0	800	8474071032	50
35		20	1,0	800	8474071035	50
40		20	1,0	800	8474071040	25
42	1 1/4"	20	1,0	800	8474071042	25
50		20	1,2	800	8474071050	25
54		20	1,2	800	8474071054	25
60	2"	20	1,2	800	8474071060	25

● CONDUIT CLIP



- 1 Over 10 mm diameter pipes, fixation hole is oblong (6x8 mm) for better adjustment
- 2 Steel thickness from 0,8 to 1,2 mm

ADVANTAGE Quick fixation with screw or nail.

TECHNICAL DATA

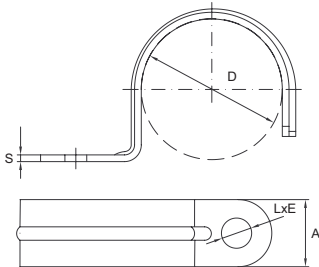

Material: W1

DIMENSIONS



FEATURES

- Support up to max. 450 N

D mm	D "	A mm	S mm	E mm	L mm		N°	
6		15	0,8	6	-	450	8480171006	100
8		15	0,8	6	-	450	8480171008	100
10	1/8"	15	0,8	6	-	450	8480171010	100
12	1/4"	15	0,8	6	8	450	8480171012	100
14		15	0,8	6	8	450	8480171014	100
15		15	0,8	6	8	450	8480171015	100
16	3/8"	15	0,8	6	8	450	8480171016	100
18		15	0,8	6	8	450	8480171018	100
20	1/2"	15	1,2	6	8	450	8480171020	100
22		15	1,2	6	8	450	8480171022	100
25		15	1,2	6	8	450	8480171025	100
26	3/4"	15	1,2	6	8	450	8480171026	100
28		15	1,2	6	8	450	8480171028	100
30		15	1,2	6	8	450	8480171030	100
32	1"	15	1,2	6	8	450	8480171032	100
37		18	1,2	6	8	450	8480171037	50
40		18	1,2	6	8	450	8480171040	50
42	1 1/4"	18	1,2	6	8	450	8480171042	50
47	1 1/2"	18	1,2	6	8	450	8480171047	50
50	1 1/2"	18	1,2	6	8	450	8480171050	50



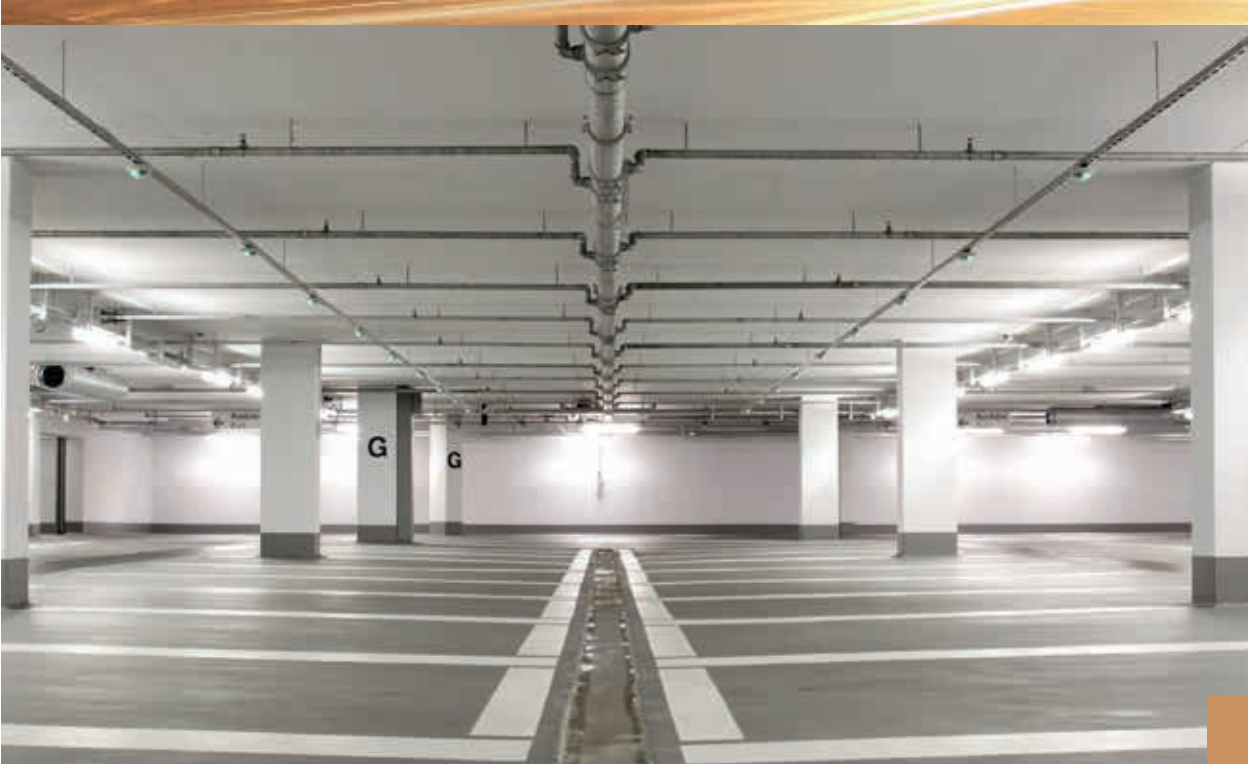

Isophonic Pipe Clamps



Usable as a fixed point, ideal for quick tube mounting. For installations with acoustic constraints. Our rubber is fitted for better resistance against expansions and vibrations. Simple pipe assembly for the building and the industry. Ideal attachment suspended under the ceiling or under supporting rail.

● ISOPHONIC QUICK CLAMP WITH HINGE M8/M10



- 1 M8/M10 nut
- 2 Band thickness: 1,2 mm
- 3 One screw with high mobility for quick installation

ADVANTAGE Hinge mechanism allows easy and wide opening.

TECHNICAL DATA

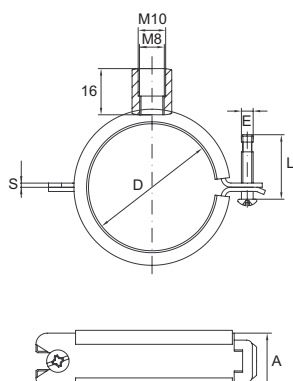

Band material: W1
Rubber: EPDM DIN 4109

DIMENSIONS



FEATURES

- Support up to max. 800 N
- Temperature resistance: -40° / +110° C

D mm	D mm	D "	A mm	S mm	E mm	L mm			N°	
14	14-15	1/4"	20	1,2	M5	22	18	800	8471571015	50
16	16-18	3/8"	20	1,2	M5	22	18	800	8471571016	50
20	20-22	1/2"	20	1,2	M5	22	18	800	8471571020	50
25	25-27	3/4"	20	1,2	M5	22	18	800	8471571025	50
28	28-30		20	1,2	M5	22	18	800	8471571028	50
33	33-35	1"	20	1,2	M5	22	18	800	8471571033	50
36	36-38		20	1,2	M5	22	18	800	8471571036	25
42	42-44	1 1/4"	20	1,2	M5	22	18	800	8471571042	25
48	48-50	1 1/2"	20	1,2	M5	22	18	800	8471571048	25
52	52-54		20	1,2	M5	22	18	800	8471571052	25
60	57-60	2"	20	1,2	M5	22	18	800	8471571060	25

● ISOPHONIC QUICK CLAMP WITH HINGE AND FIXING M8/M10



- 1 M8/M10 nut
- 2 Band thickness: 1,2 mm
- 3 One screw for quick installation
- 4 Fixing system: screw retaining and free movement allowance

ADVANTAGE Hinge mechanism allows easy and wide opening.

TECHNICAL DATA

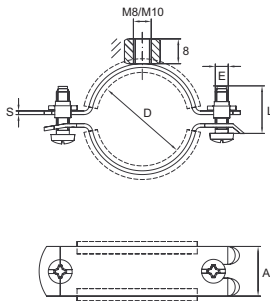

Band material: W1
Rubber: EPDM DIN 4109

DIMENSIONS



FEATURES

- Support up to max. 800 N
- Temperature resistance: -40° / +110° C

D mm	D mm	D "	A mm	S mm	E mm	L mm			N°	
15	14-15	1/4"	20	1,2	M5	25	18	800	8471771015	100
18	16-19	3/8"	20	1,2	M5	25	18	800	8471771018	100
22	21-23	1/2"	20	1,2	M5	25	18	800	8471771022	100
28	26-28	3/4"	20	1,2	M5	25	18	800	8471771028	100
35	32-35	1"	20	1,2	M5	25	18	800	8471771035	100
40	40-43	1 1/4"	20	1,2	M5	25	18	800	8471771040	50
48	48-51	1 1/2"	20	1,2	M5	25	18	800	8471771048	50
54	52-56	-	20	1,2	M5	25	18	800	8471771054	50
60	57-60	2"	20	1,2	M5	25	18	800	8471771060	50
75	74-80	2 1/2"	20	1,5	M5	25	18	800	8471771075	50
90	83-91	3"	20	1,5	M5	25	18	800	8471771090	50

● ISOPHONIC PIPE CLAMP M8/M10 WITH CAPTIVE SCREWS

For ventilation and aerualics



- 1 M8/M10 nut
- 2 2 unloss M6 screws with plastic washers
- 3 Band thickness : 2 to 2,5 mm

ADVANTAGE Plastic washers avoid the loss of side screws.

TECHNICAL DATA

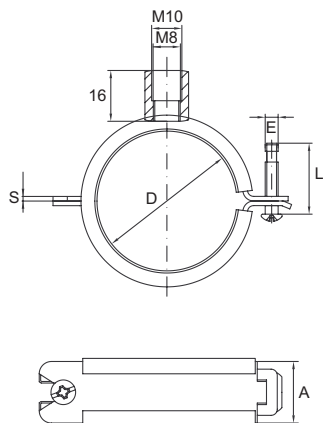

Band material: W1
Rubber: EPDM DIN 4109

DIMENSIONS



FEATURES

- Support up to max. 2000 N
- Temperature resistance: -40° / +110° C

D mm	D mm	D "	A mm	S mm	E mm	L mm			N°	
18	15-19	3/8"	20	2,0	M6	15	18	2000	8471871018	50
22	20-25	1/2"	20	2,0	M6	15	18	2000	8471871022	50
28	26-30	3/4"	20	2,0	M6	15	18	2000	8471871028	50
35	32-36	1"	20	2,0	M6	15	18	2000	8471871035	50
40	38-43	1 1/4"	20	2,0	M6	20	18	2000	8471871040	25
48	47-51	1 1/2"	20	2,0	M6	20	18	2000	8471871048	25
54	53-56		20	2,0	M6	20	18	2000	8471871054	25
60	60-64	2"	20	2,0	M6	20	18	2000	8471871060	25
70	68-72		20	2,0	M6	20	18	2000	8471871070	25
75	75-80	2 1/2"	20	2,0	M6	20	18	2000	8471871075	25
83	81-86		20	2,0	M6	20	18	2000	8471871083	25
90	87-92	3"	20	2,0	M6	20	18	2000	8471871090	25
100	99-105	3 1/2"	20	2,0	M6	20	18	2000	8471871100	25
110	107-112		20	2,0	M6	20	18	2000	8471871110	25
115	113-118	4"	20	2,0	M6	20	18	2000	8471871115	25
125	125-130		20	2,0	M6	26	18	2000	8471871125	25
133	132-137		20	2,0	M6	26	18	2000	8471871133	25
140	138-142	5"	20	2,0	M6	26	18	2000	8471871140	25
150	148-152		20	2,0	M6	26	18	2000	8471871150	25
160	159-166	6"	20	2,0	M6	26	18	2000	8471871160	25
168	168-172		20	2,5	M6	26	18	2000	8471871168	25
180	179-184		20	2,5	M6	26	18	2000	8471871180	25
200	199-205		20	2,5	M6	26	18	2000	8471871200	25
220	215-220	8"	20	2,5	M6	26	18	2000	8471871220	25
224	223-228		20	2,5	M6	26	18	2000	8471871224	25
250	249-254		20	2,5	M6	26	18	2000	8471871250	25
300	299-304		20	2,5	M6	26	18	2000	8471871300	25
315	314-319		20	2,5	M6	26	18	2000	8471871315	25
355	354-359		20	2,5	M6	26	18	2000	8471871355	25
400	399-404		20	2,5	M6	26	18	2000	8471871400	25
450	449-454		20	2,5	M6	26	18	2000	8471871450	10
500	499-504		20	2,5	M6	26	18	2000	8471871500	10

● ISOPHONIC HEAVY DUTY PIPE CLAMP M12

Heavy duty application: cast iron pipe



- 1 M12 nut
- 2 2 unloss M8 or M10
- 3 Band thickness: 2 to 3 mm

DIMENSIONS

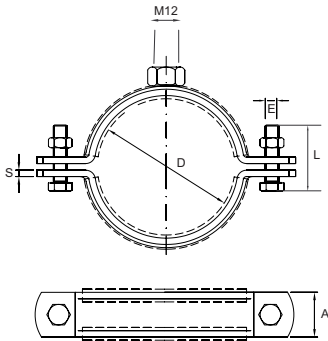



TECHNICAL DATA

Band material: W1
Rubber: EPDM DIN 4109

FEATURES

- Support up to max. 3300 N
- Side screws:
 - M8 for D22 to D110
 - M10 for D140 to D220
- Temperature resistance: -40° / +110° C

D mm	D mm	D "	A mm	S mm	E mm	L mm			N°	
22	20-24	1/2"	25	2	M8	25	18	2750	8471971022	50
28	25-30	3/4"	25	2	M8	25	18	2750	8471971028	50
35	32-38	1"	25	2	M8	25	18	2750	8471971035	50
40	39-46	1 1/4"	25	2	M8	25	18	2750	8471971040	50
48	48-53	1 1/2"	25	2	M8	25	18	2750	8471971048	50
60	59-66	2"	25	2	M8	25	18	2750	8471971060	40
75	74-80	2 1/2"	25	2	M8	25	18	2750	8471971075	30
90	87-94	3"	25	2	M8	25	18	2750	8471971090	30
110	108-116	4"	30	2,5	M8	25	18	2750	8471971110	30
140	135-143	5"	30	3	M10	30	18	2750	8471971140	10
160	162-168	6"	30	3	M10	30	18	2750	8471971160	10
220	206-220	8"	30	3	M10	30	18	2750	8471971220	10

● M8 ISOPHONIC GUTTER PIPE CLAMP



- 1 Riveted M8 nut
- 2 2 unloss M6 screws with plastic washers
- 3 Band thickness: 1 mm

DIMENSIONS

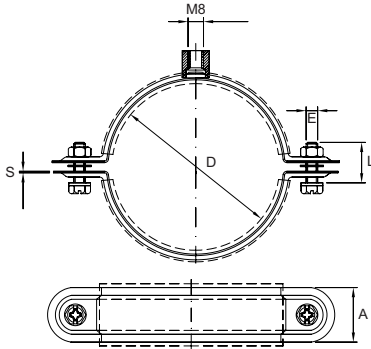



TECHNICAL DATA

Band material: W1
Rubber: EPDM DIN 4109

FEATURES

- Support up to max. 1000 N
- Temperature resistance: -40° / +110° C

D mm	D mm	D "	A mm	S mm	E mm	L mm			N°	
75	75-80	2 1/2"	28	1	M6	20	18	1000	8471471075	50
90	82-90	3"	28	1	M6	20	18	1000	8471471090	50
110	106-112	3 1/2"	28	1	M6	20	18	1000	8471471110	50
125	124-130	4"	28	1	M6	20	18	1000	8471471125	50

● BRIDGE ISOPHONIC PIPE CLAMP



- 1 All in a piece
- 2 Hasp for easy installation

ADVANTAGE Moldable: easy twisting and allows to adapt itself to pipes of various diameters.

TECHNICAL DATA

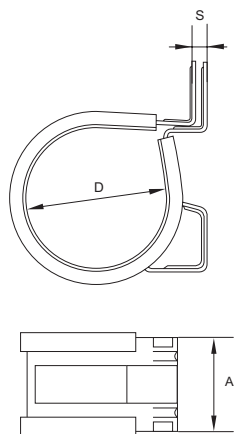

Band material: W1
Rubber: EPDM DIN 4109

DIMENSIONS



FEATURES

- Support up to max. 800 N
- Temperature resistance: -40° / +110° C

D mm	D "	A mm	S mm	 dB	 N	N°	
12	1/4"	20	0,8	18	450	8472071012	50
15	1/4"	20	0,8	18	450	8472071015	50
16	3/8"	20	0,8	18	450	8472071016	50
18	3/8"	20	0,8	18	450	8472071018	50
20	1/2"	20	0,8	18	450	8472071020	50
22	1/2"	20	0,8	18	450	8472071022	50
25	1/2"	20	0,8	18	450	8472071025	50
28	3/4"	20	1,0	18	450	8472071028	50
32	1"	20	1,0	18	800	8472071032	50
35	1"	20	1,0	18	800	8472071035	50
40	1"	20	1,0	18	800	8472071040	25
42	1 1/4"	20	1,0	18	800	8472071042	25
50	1 1/4"	20	1,2	18	800	8472071050	25
54	1 1/4"	20	1,2	18	800	8472071054	25
60	2"	20	1,2	18	800	8472071060	25

● INSULATED PIPE CLAMP 13MM – M8/M10



- 1 M8/M10 nut
- 2 2 unloss M6 screws

ADVANTAGE Wide opening clamp for easy installation.

TECHNICAL DATA

Material: Elastomeric foam
 Heat conductivity: 0.036W(m.k) à 0
 Compression resistance factor ≥ 7000
 Density: 80 Kg/cm³ (± 8)

DIMENSIONS

FEATURES

- Temperature resistance: -45° / +105° C

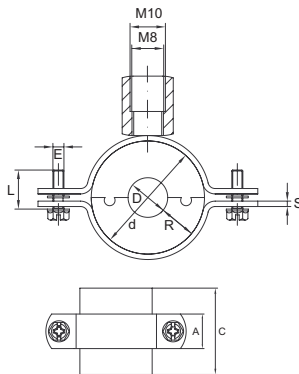

D mm	D ''	A mm	S mm	d mm	E mm	L mm	R mm	C mm	N°	
15-17	1/4"	20	2	41	M6	26	13	42	8472071015	10
18-21	3/8"	20	2	44-51	M6	26	13	42	8472071018	10
22-24	1/2"	20	2	47-54	M6	26	13	42	8472071022	10
28-30	3/4"	20	2	53-60	M6	26	13	42	8472071028	10
35-37	1"	20	2	62-69	M6	26	13	42	8472071035	10
42-44	1 1/4"	20	2	69-76	M6	26	13	42	8472071042	10
48-50	1 1/2"	20	2	75-82	M6	26	13	42	8472071048	10
54-56	-	20	2	81-88	M6	26	13	42	8472071054	10
60-62	2"	20	2	89-96	M6	26	13	42	8472071060	10
64-66	-	20	2	93-100	M6	26	13	42	8472071064	5
75-78	2 1/2"	20	2	105-112	M6	26	13	42	8472071075	5
89-91	3"	20	2	118-125	M6	26	13	42	8472071090	5
114-116	4"	20	2	143-150	M6	26	13	42	8472071115	5

● INSULATED PIPE CLAMP 19MM – M8/M10



- 1 M8/M10 nut
- 2 2 unloss M6 screws

ADVANTAGE Wide opening clamp for easy installation.

TECHNICAL DATA

Material: Elastomeric foam
 Heat conductivity: 0.036W(m.k) à 0
 Compression resistance factor ≥ 7000
 Density: 80 Kg/cm³ (± 8)

DIMENSIONS

FEATURES

- Temperature resistance : -45° / +105° C

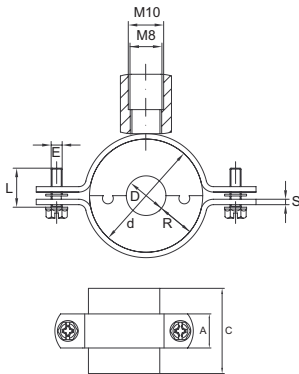

D mm	D "	A mm	S mm	d mm	E mm	L mm	R mm	C mm	N°	
15-17	1/4"	20	2	53	M6	26	19	42	8472171015	10
18-21	3/8"	20	2	58-65	M6	26	19	42	8472171018	10
22-24	1/2"	20	2	61-68	M6	26	19	42	8472171022	10
28-30	3/4"	20	2	67-74	M6	26	19	42	8472171028	10
35-37	1"	20	2	74-81	M6	26	19	42	8472171035	10
42-44	1 1/4"	20	2	83-90	M6	26	19	42	8472171042	10
48-50	1 1/2"	20	2	89-96	M6	26	19	42	8472171048	10
54-56	-	20	2	95-102	M6	26	19	42	8472171054	10
60-62	2"	20	2	101-108	M6	26	19	42	8472171060	10
64-66	-	20	2	105-112	M6	26	19	42	8472171064	5
75-78	2 1/2"	20	2	119-126	M6	26	19	42	8472171075	5
89-91	3"	20	2	132-139	M6	26	19	42	8472171090	5
114-116	4"	20	2	161-168	M6	26	19	42	8472171115	5



Plastic Clip



All of our clips can be implemented quickly. No sharp edges. Can be used indoor or outdoor. Thin walled copper or steel tubes for horizontal or vertical mounting. Resistant to oil and petrol, corrosion, UV and ageing. Our clips are halogen free. Recyclable.

● SIMPLE & DOUBLE PLASTIC CLIP M6

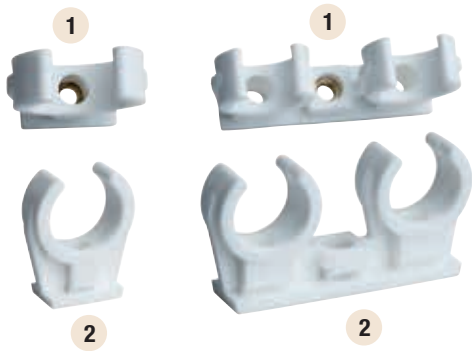

- 1 M6 Brass socket
- 2 Can be fixed:
 - with M6 threaded screw
 - On channels

ADVANTAGE Can be used for inside or outside applications.

TECHNICAL DATA

Material: PA6

DIMENSIONS

FEATURES

- Temperature resistance : -40° / +100° C
- Halogen free
- Ultraviolet, oils, petrol, corrosion and ageing resistant.

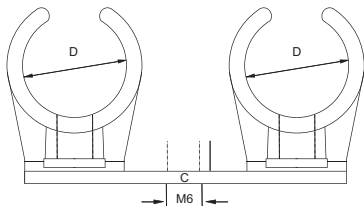
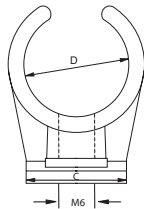

D mm	D "	C mm	N°	
8		14	8590876208	100
10	1/8"	18	8590876210	100
12	1/4"	20	8590876212	100
15	3/8"	24	8590876215	100
16-18		27	8590876218	100
20-22	1/2"	31	8590876222	100
25	3/4"		8590876225	100
28		39	8590876228	100
32	1"		8590876232	50
35		50	8590876235	50
42	1 1/4"		8590876242	50

D mm	D "	C mm	N°	
8		40	8590976208	100
10	1/8"	45	8590976210	100
12	1/4"	53	8590976212	100
15	3/8"	60	8590976215	100
16-18		65	8590976218	100
20-22	1/2"	73	8590976222	50
28		89	8590976228	50



Channels





Our rails allow quick tube fastening

With our wide range of accessories you have a multitude of mounting options. Engraved markings on the sides and rail lips make it easy to adjust and cut different elements. High bending resistance due to the profile's shape. We offer a soundproof strip adapted to each type of rail. You can create a neat finish with the end caps.

Our consoles are ideal as support

The welded plate is very resistant and its oblong slots allow vertical adjustment. Our consoles have different lengths corresponding to most mounting options. Various combinations are possible with our bases and our assembly wall lamps. You can create a neat finish with the end caps.

GUIDE FOR C-SHAPE CHANNEL

CHANNELS				
		27/18	28/30	38/40
CHANNEL SCREW		✓	✓	✓
FIXING PLATE		✓	✓	✓
		✓	✓	✓
		✓	✓	✓
HORIZONTAL & VERTICAL SUPPORT		✓	✓	✓
		✓	✓	✓
CAPS		✓	✓	✓

● CHANNEL 27/18 C-SHAPE



DIMENSIONS

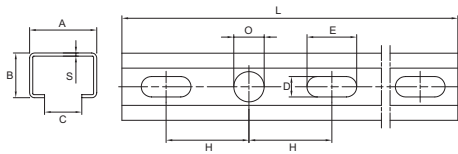

TECHNICAL DATA

Finishing: Sendzimir

Length: 2000 mm, thickness: 1,20 mm

A mm	B mm	C mm	S mm	D mm	E mm	H mm	O mm	L mm	N°	
27	18	15	1,2	8	20	35	12	2000	2837012027	12

● CHANNEL 28/30 C-SHAPE



DIMENSIONS

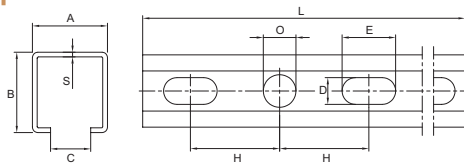

TECHNICAL DATA

Finishing: Sendzimir

Length: 2000 mm, thickness: 1,80 mm

A mm	B mm	C mm	S mm	D mm	E mm	H mm	O mm	L mm	N°	
28	30	15	1,8	10	20	35	12	2000	2837013028	12

● CHANNEL 38/40 C-SHAPE



DIMENSIONS

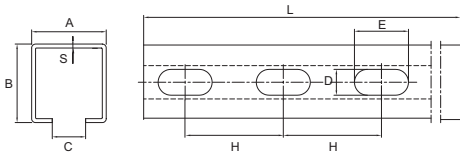

TECHNICAL DATA

Finishing : Sendzimir

Length: 2000 or 3000 mm, thickness: 2,00 mm

A mm	B mm	C mm	S mm	D mm	E mm	H mm	L mm	N° S*	
38	40	17	2	13,2	27,5	50	2000	2837014101	8
38	40	17	2	13,2	27,5	50	3000	2837014102	4

● CANTILEVER 27/18 C-SHAPE



DIMENSIONS

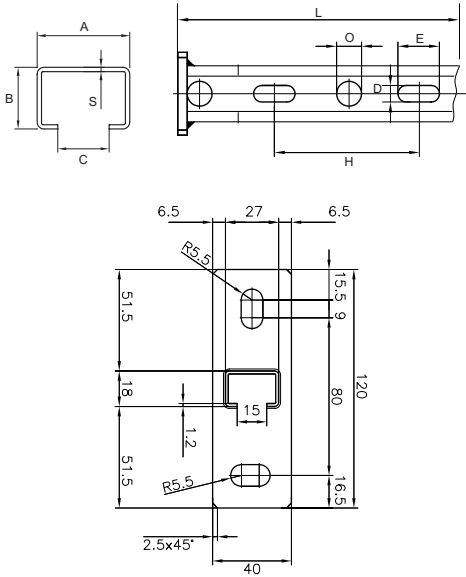

TECHNICAL DATA

Material: W1 - Zinc Plated Steel

Length 200 mm or 300 mm, thickness: 1,20 mm

A mm	B mm	C mm	S mm	D mm	E mm	H mm	O mm	L mm	N°	
27	18	15	1,2	8	20	33	12	200	2837021200	20
27	18	15	1,2	8	20	33	12	300	2837021300	20

● CANTILEVER 28/30 C-SHAPE

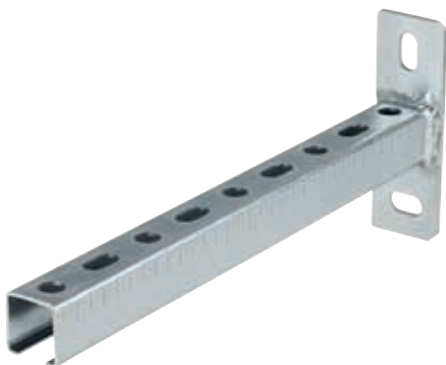

DIMENSIONS

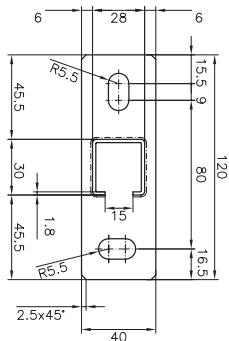
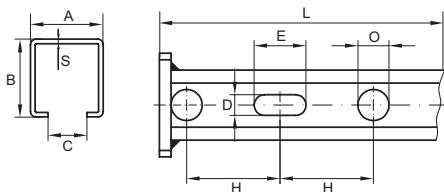

TECHNICAL DATA

Material: W1 - Zinc Plated Steel
 Length 200 mm, 300 mm or 600 mm,
 thickness: 1,80 mm

A mm	B mm	C mm	S mm	D mm	E mm	H mm	O mm	L mm	N°	
28	30	15	1,8	8	20	33	12	200	2837022200	20
28	30	15	1,8	8	20	33	12	300	2837022300	20
28	30	15	1,8	8	20	33	12	600	2837022600	20

● CHANNEL SCREW FOR C-SHAPE CHANNEL



DIMENSIONS

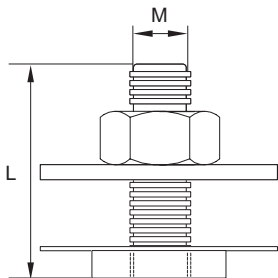



TECHNICAL DATA

Material: W1 - Zinc Plated Steel
W4 available

FEATURES

- Allow quick installation on C-Shape channels
- Quick positioning after installation due to the fixing mechanism, with free longitudinal movement in the channel

Rail type	M	L mm	 mm	N°	
27/18-28/30	M6	20	6x18	2837031620	100
27/18-28/30	M8	20	8x24	2837031820	100
27/18-28/30	M8	30	8x24	2837031830	100
27/18-28/30	M10	30	10x30	2837031930	100
38/40	M8	30	8x24	2837032830	100
38/40	M8	40	8x24	2837032840	100
38/40	M10	30	10x30	2837032930	100
38/40	M10	40	10x30	2837032940	100

● FIXING PLATE FOR C-SHAPE CHANNEL

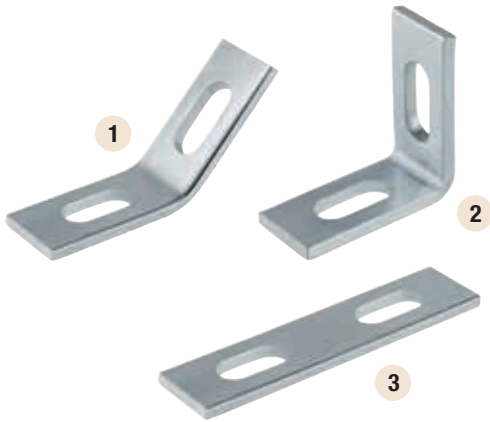

- 1 45° Fixing Plate
- 2 90° Fixing Plate
- 3 0° Fixing Plate

DIMENSIONS

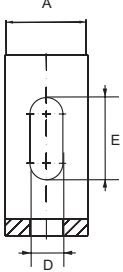
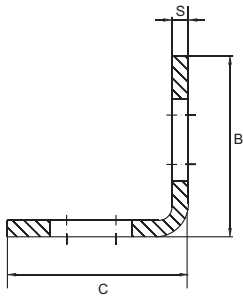
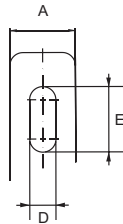
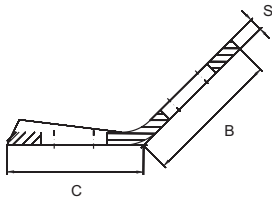

TECHNICAL DATA

Material: W1

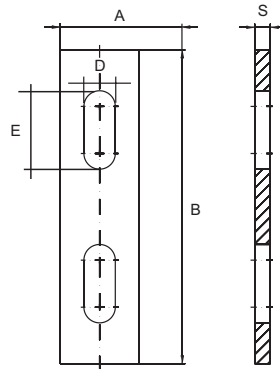

Tilt °	A mm	S mm	B mm	C mm	D mm	E mm	N°	
45°	25	5	52	52	10	25	2837034045	100
90°	25	5	55	55	10	25	2837034090	100
0°	25	5	100	-	10	25	2837035000	100

● VERTICAL & HORIZONTAL SUPPORT FOR C-SHAPE CHANNEL



- 1 Horizontal support
- 2 Vertical support

DIMENSIONS

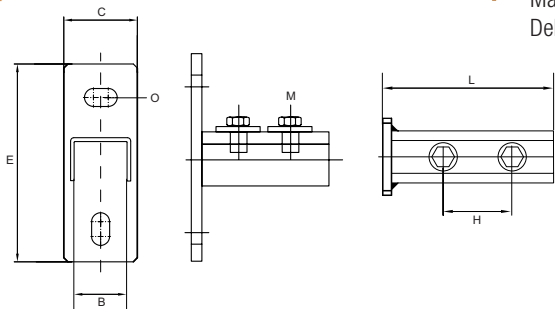

TECHNICAL DATA





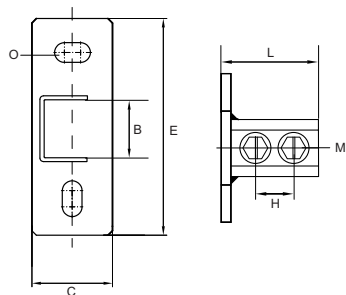







Material: W1
Delivered with 2 x M10 screws

Channel type	M	B mm	C mm	O mm	E mm	H mm	L mm	N°	
27/18-28/30	M10	30	40	11	120	20	80	2837041127	50
38/40	M10	30	40	11	120	20	80	2737041138	50



Channel type	M	B mm	C mm	O mm	E mm	H mm	L mm	N°	
27/18-28/30	M10	20	40	11	120	20	80	2837042227	50
38/40	M10	20	40	11	120	20	80	2837042238	50

GUIDE FOR STRUT 41-SHAPE CHANNEL

CHANNELS			
		41/21	41/41
CHANNEL NUT		✓	✓
CHANNEL SCREW		✓	✓
U PLATE		✓	✓
FIXING PLATE		✓	✓
		✓	✓
		✓	✓
REINFORCED SQUARE		✓	✓
DOUBLE BASE		✓	✓
BRIDGE		-	✓
BEAM CLAMP		✓	✓
CAPS		✓	✓

● CHANNEL 41/21 STRUT 41-SHAPE

For heavy duty application



DIMENSIONS

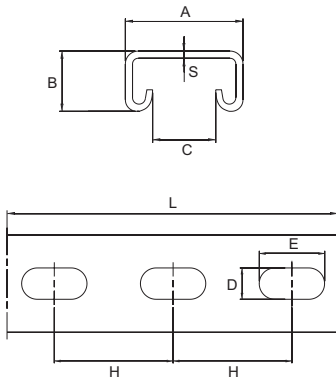

TECHNICAL DATA

Finishing: Sendzimir

Length: 3000 mm

Thickness: 2,00 mm and 2,50 mm



A mm	B mm	C mm	S mm	D mm	E mm	H mm	L mm	N°	
41	21	22	2	13,2	27,5	50	3000	2837051403	4
41	21	22	2,5	13,2	27,5	50	3000	2837051401	4

● CHANNEL 41/41 STRUT 41-SHAPE

For heavy duty application



DIMENSIONS

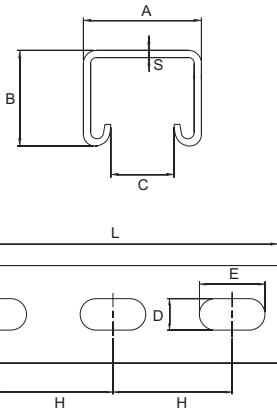

TECHNICAL DATA

Finishing: Sendzimir
 Length: 3000 mm and 6000 mm
 Thickness: 2,00 mm and 2,50 mm



A mm	B mm	C mm	S mm	D mm	E mm	H mm	L mm	N°	
41	41	22	2	13,2	27,5	50	3000	2837052503	4
41	41	22	2	13,2	27,5	50	6000	2837052504	1
41	41	22	2,5	13,2	27,5	50	3000	2837052501	4
41	41	22	2,5	13,2	27,5	50	6000	2837052502	1

● CANTILEVER 41/21 STRUT 41 SHAPE

For heavy duty application



DIMENSIONS

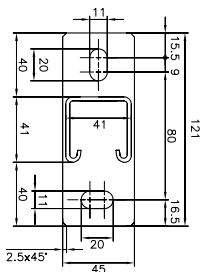
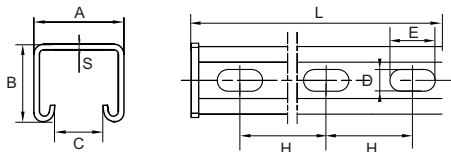

TECHNICAL DATA

Finishing: Zinc Plated Steel
 Length: 150 mm, 300 mm, 450 mm
 Thickness: 2,50 mm



A mm	B mm	C mm	S mm	D mm	E mm	H mm	L mm	N° ZB	
41	21	22,3	2,5	13,2	27,5	50	150	2837061150	20
41	21	22,3	2,5	13,2	27,5	50	300	2837061300	20
41	21	22,3	2,5	13,2	27,5	50	450	2837061450	10

● CANTILEVER 41/41 STRUT 41 SHAPE

For heavy duty application



DIMENSIONS

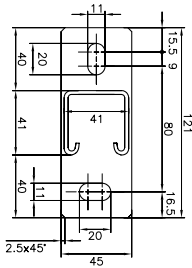
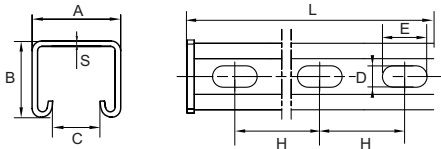

TECHNICAL DATA

Finishing : Zinc Plated Steel
 Length: 150 mm to 1000 mm
 Thickness: 2,50 mm



A mm	B mm	C mm	S mm	D mm	E mm	H mm	L mm	N° ZB	
41	41	22	2,5	13,2	27,5	50	200	2837063250	10
41	41	22	2,5	13,2	27,5	50	300	2837063300	10
41	41	22	2,5	13,2	27,5	50	400	2837063450	10
41	41	22	2,5	13,2	27,5	50	500	2837063550	10
41	41	22	2,5	13,2	27,5	50	600	2837063600	10
41	41	22	2,5	13,2	27,5	50	750	2837063750	10
41	41	22	2,5	13,2	27,5	50	1000	2837063999	10

● U PLATE FOR STRUT 41 SHAPE



DIMENSIONS

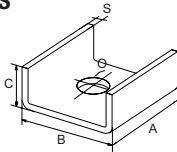

TECHNICAL DATA

Material: W1



A mm	B mm	C mm	S mm	O mm	N°	
40	45	20	4	14	2837078001	50

● CHANNEL NUT FOR STRUT 41 SHAPE



DIMENSIONS

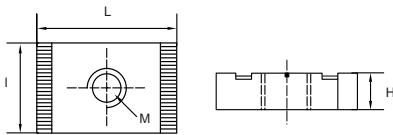

TECHNICAL DATA

Material: W1



M	H mm	L mm	I mm	N°	
M6	6	34,5	19	2837071001	100
M8	6	34,5	19	2837072101	100
M10	8	34,5	19	2837073201	100
M12	8	34,5	19	2837074301	100

● CHANNEL SCREW FOR STRUT 41 SHAPE



DIMENSIONS

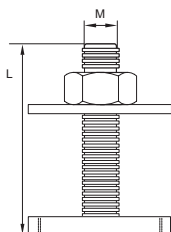

TECHNICAL DATA

Material: W1



M	L mm	Nut mm	N°	
M8	20	8x24	2837077301	50
M8	30	8x24	2837077302	50
M8	40	8x24	2837077303	50
M8	50	8x24	2837077304	50
M8	60	8x24	2837077305	50
M10	30	10x30	2837077306	50
M10	40	10x30	2837077307	50
M10	50	10x30	2837077308	50
M10	60	10x30	2837077309	50
M12	40	13x40	2837077310	25
M12	60	13x40	2837077311	25

● 135° FIXING PLATE FOR STRUT 41 SHAPE



DIMENSIONS

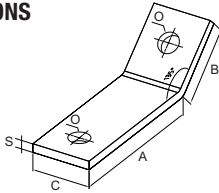

TECHNICAL DATA

Material: W1



Tilt °	A mm	B mm	S mm	C mm	O mm	N°	
135	86	52	5	40	14	2837079001	25

● 90° FIXING PLATE FOR STRUT 41 SHAPE - 2 SLOTS

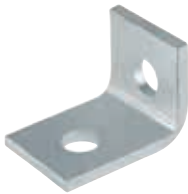

DIMENSIONS

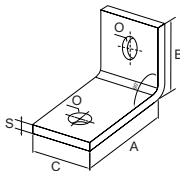

TECHNICAL DATA

Material: W1



Tilt °	A mm	B mm	S mm	C mm	O mm	N°	
90	57	42	5	40	14	2837071202	50

● 90° FIXING PLATE FOR STRUT 41 SHAPE - 3 SLOTS



DIMENSIONS

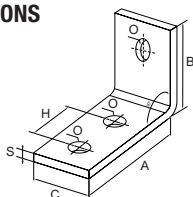

TECHNICAL DATA

Material: W1

41

Tilt °	A mm	B mm	S mm	C mm	H mm	O mm	N°	
90	88	68	5	40	46	14	2837071403	50

● REINFORCED SQUARE FOR STRUT 41 SHAPE – 4 SLOTS



DIMENSIONS

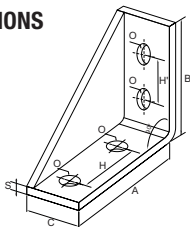

TECHNICAL DATA

Material: W1

41

A mm	B mm	C mm	S mm	O mm	H mm	H' mm	N°	
103	83	46	5	14	45	40	2837071604	20

● DOUBLE BASE FOR STRUT 41 SHAPE

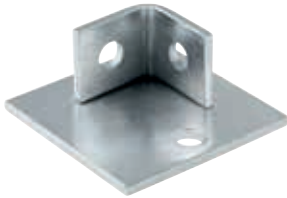

DIMENSIONS

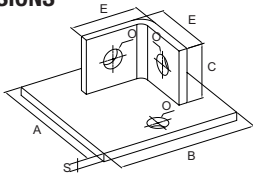

TECHNICAL DATA

Material: W1

41

A mm	B mm	C mm	S mm	E mm	O mm	N°	
100	100	40	5	50	14	2837071810	20

● BRIDGE 5 SLOTS FOR STRUT 41 SHAPE

For Channel Strut 41/41 Shape assembly



DIMENSIONS

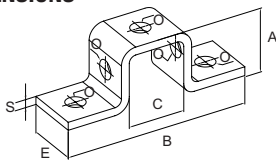

TECHNICAL DATA

Material: W1

41

A mm	B mm	C mm	S mm	E mm	O mm	N°	
47	136	42	5	40	14	2837072105	20

● BEAM CLAMP M10 FOR STRUT 41 SHAPE

For Channel Strut 41 Shape



DIMENSIONS

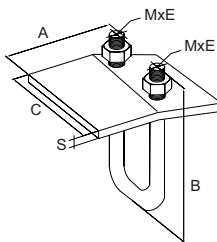

TECHNICAL DATA

Material: W1

Finishing: Hot dip galvanization



A mm	B mm	C mm	S mm	M mm	E mm	N°	
124	120	90	4	40	M10	2837072201	50

● C & STRUT 41 SHAPE CHANNEL CONNECTION

For Strut 41 and 38/40 C-Shape channel assembly

AVAILABLE MID-2013



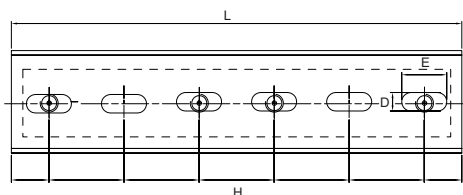
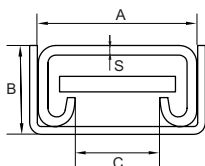

DIMENSIONS



TECHNICAL DATA

Finishing: Sendzimir or Dacromet

A mm	B mm	C mm	S mm	D mm	E mm	H mm	L mm
41,5	21	22	2	8	20	33,33	200

N° S*		N° D**	
2837084101	10	2837084102	10

* S=Sendzimir

** D=Dacromet

● CAPS FOR C AND STRUT 41 SHAPE CHANNEL

Safety caps for channels C-Shape 27/18, 28/30, 38/40, and Strut 41-Shape 41/21, 41/41



DIMENSIONS

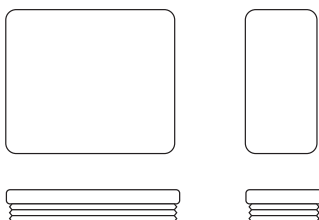

TECHNICAL DATA

Material: black plastic

Profile type	N°	
27/18	2837085027	100
28/30	2837085028	100
38/40	2837085038	100
41/21	2837085041	100
41/41	2837085042	100







Accessories



Fastening solutions for different types of supporting applications. Our product is ideal for light and heavy support creation. Our accessories allow quick implementation.

GUIDE FOR FIXING PARTS

			
		Metal	Solid structure
THREADED SCREW		-	✓
DOUBLE THREAD SCREW		-	✓

GUIDE FOR ANCHORS

			
		Metal	Solid structure
SCREW ANCHOR		-	✓
WEDGE ANCHOR		-	✓
BRASS ANCHOR		-	✓
DROP IN ANCHOR		-	✓

				
Hollow structure	Concrete	Aerated concrete	Wood	Plaster board
✓	✓	-	✓	✓
✓	✓	-	✓	✓

				
Hollow structure	Concrete	Aerated concrete	Wood	Plaster board
-	✓	-	-	-
-	✓	-	-	-
-	✓	-	-	-
-	✓	-	-	-

● THREADED SCREWS

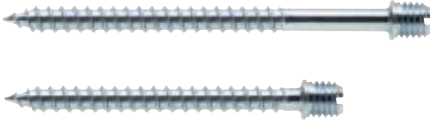

DIMENSIONS

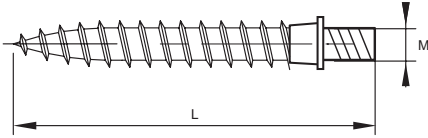



TECHNICAL DATA

Material: W1

M mm	L mm	N°	
M6	30	2827011630	100
M6	40	2827011640	100
M6	50	2827011650	100
M8	40	2827011840	100
M8	60	2827011860	100
M8	80	2827011880	100
M10	50	2827011105	100
M10	70	2827011107	100

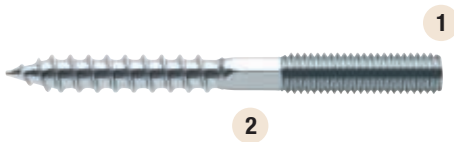
● DOUBLE THREAD SCREW



- 1 Torx footprint  enables an easy tightening with a better torque transmission
- 2 Hexagonal shape for easy tightening

DIMENSIONS

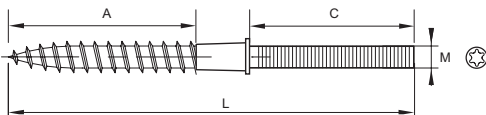

TECHNICAL DATA

Material: W1

M mm	L mm	A mm	C mm	N°	
M8	50	30	10	2827012850	100
M8	80	40	30	2827012880	100
M10	80	40	30	2827013107	100

● HEXAGONAL NUT



DIMENSIONS

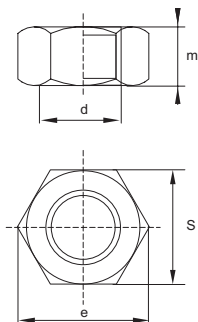

TECHNICAL DATA

Material: W1
Class 8 – DIN 934

d	DIN	m mm	S mm	e mm	N°	
M8	934	6,5	13	14,3	2827022008	200
M10	934	8	16	18,9	2827022010	100
M12	934	10	18	21	2827022012	50

● LARGE WASHER



DIMENSIONS

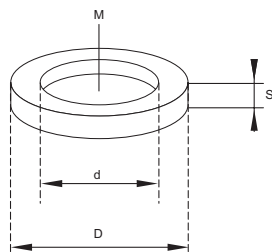

TECHNICAL DATA

Material: W1
Spec: DIN 9021

M	DIN	D mm	d mm	S mm	N°	
M8	9021	24	8,4	2	2827024008	200
M10	9021	30	10,5	2,5	2827024010	200
M12	9021	37	13	3	2827024012	100

● SCREW ANCHOR



DIMENSIONS

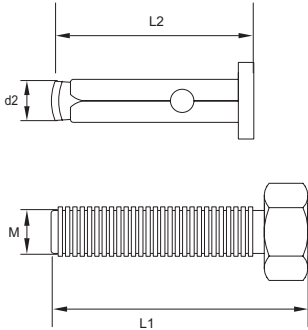

TECHNICAL DATA

Material: W1

M	L1 mm	d2 mm	L2 mm	N°	
M8	60	10	60	2827044860	100
M8	80	10	80	2827044880	100
M10	70	12	70	2827044070	50
M10	100	12	100	2827044100	50

● WEDGE ANCHOR



DIMENSIONS

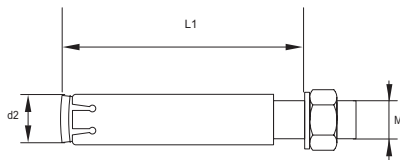

TECHNICAL DATA

Material: W1

M	L1 mm	d2 mm	N°	
M8	75	8	2827048875	100
M8	90	8	2827048890	100
M10	70	10	2827048075	100
M10	90	10	2827048090	100
M10	120	10	2827048101	25
M10	150	10	2827048150	25

● BRASS ANCHOR



DIMENSIONS

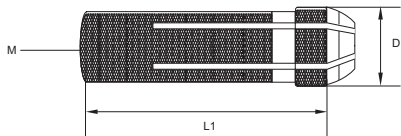

TECHNICAL DATA

Material: Brass

M	L1 mm	D mm	N°	
M6	23	8	2827049623	200
M8	30	10	2827049830	100

● DROP-IN ANCHOR



DIMENSIONS

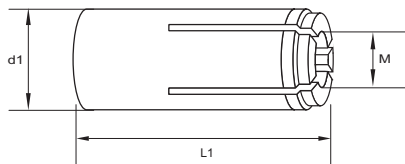

TECHNICAL DATA

Material: W1

M	L1 mm	d1 mm	N°	
M6	26	8	2827049623	200
M8	32	10	2827049830	100

● THREADED ROD



DIMENSIONS

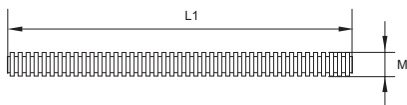

TECHNICAL DATA

Material: W1

Spec: DIN 975

M	L1 mm	N°	
M4	1000	2827063004	100
M5	1000	2827063005	100
M6	1000	2827063006	100
M7	1000	2827063007	50
M8	1000	2827063008	50
M10	1000	2827063010	25
M12	1000	2827063012	20

● THREADED PINS



DIMENSIONS

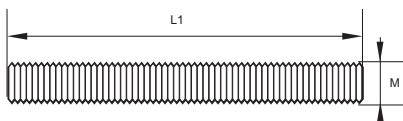

TECHNICAL DATA

Material: W1

Spec: DIN 976/A

M	L1 mm	N°	
M6	20	2827064620	200
M6	30	2827064630	200
M8	20	2827064820	200
M8	30	2827064830	200
M10	30	2827064103	100
M12	30	2827064123	100

● DOUBLE THREADED SCREW



DIMENSIONS

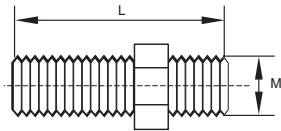

TECHNICAL DATA

Material: W1

M	L mm	N°	
M6	22	2827065066	100
M7	27	2827065077	100

● ELEVATION NUT



DIMENSIONS

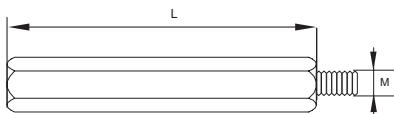

TECHNICAL DATA

Material: W1

M	L mm	N°	
M7	20	2827067620	100
M7	30	2827067630	100
M7	40	2827067640	100
M7	60	2827067660	100

● COUPLING NUT



- 1 Cylindric elevation nut
- 2 Hexagonal elevation nut

DIMENSIONS

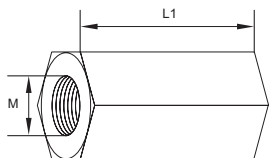
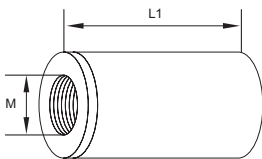

TECHNICAL DATA

Material: X1

M	L1 mm	N°	
M7	30	2827069730	100

M	L1 mm	N°	
M7	20	2827068720	100

● ROUND BASE PLATE

1



1 M8 or M10 nut

2 M8/M10 nut

2



DIMENSIONS

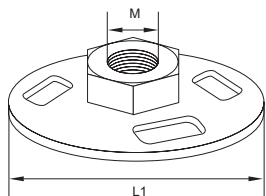

TECHNICAL DATA

Material: W1

M	L1 mm	N°	
M8	50	2827061001	100
M10	50	2827061002	100
M8/10	50	2827061003	100

● PERFORATED BAND



DIMENSIONS

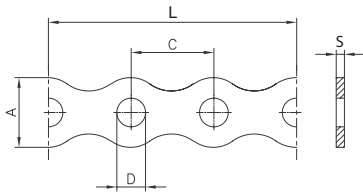



TECHNICAL DATA

Material: W1

FEATURES

- Delivered in plastic drum

L mm	A mm	S mm	C mm	D mm		N°	
10	12	0,8	14,5	5	560	2821071012	10
10	17	0,8	20,2	7	800	2821071017	10
10	26	1	25	8	1800	2821071026	10

● CABLE TIE – White and Black



- 1 Material with low coefficient of friction and enlarged end: faster installation

ADVANTAGE Cable tie for securing cables in electrical installations, industrial wiring, ... Made of polyamide 6.6. Resistant to extreme temperatures and numerous external agents (bases, oils, greases, ...). Quick and safe assembly. The black cable tie offers excellent resistant to UV rays thanks to added "carbon black".

TECHNICAL DATA

Material: Polyamide 6.6

DIMENSIONS

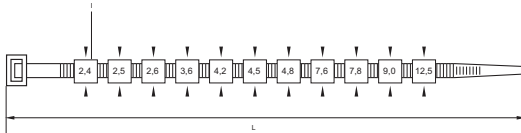

FEATURES

- Available in other colors



Size (mm)	→ Bundle max (mm)	Tensile strength (kgs)	BLACK color N°	WHITE color N°	
2,5x98	21	8	860 0210 201	860 110 201	100
2,6x160	40	8	860 0210 302	860 0110 302	100
2,6x200	52	8	860 0210 303	860 0110 303	100
3,6x140	35	13	860 0210 401	860 0110 401	100
3,6x200	50	13	860 0210 402	860 0110 402	100
3,6x290	80	13	860 0210 403	860 0110 403	100
3,6x370	103	13	860 0210 404	860 0110 404	100
4,5x120	24	20	860 0210 501	860 0110 501	100
4,5x160	40	20	860 0210 502	860 0110 502	100
4,8x178	45	22	860 0210 601	860 0110 601	100
4,8x200	50	22	860 0210 602	860 0110 602	100
4,8x250	68	22	860 0210 603	860 0110 603	100
4,8x290	79	22	860 0210 604	860 0110 604	100
4,8x360	103	22	860 0210 605	860 0110 605	100
4,8x390	106	22	860 0210 606	860 0110 606	100
4,8x430	115	22	860 0210 607	860 0110 607	100
7,8x180	45	55	860 0210 702	860 0110 702	100
7,8x240	63	55	860 0210 703	860 0110 703	100
7,8x300	80	55	860 0210 704	860 0110 704	100
7,8x365	100	55	860 0210 705	860 0110 705	100
7,8x450	130	55	860 0210 706	860 0110 706	100
7,8x540	158	55	860 0210 707	860 0110 707	100
9x780	233	77	860 0210 801	860 0110 801	100
12,6x500	143	110	860 0210 902	860 0110 902	50
12,6x1000	302	110	860 0210 905	860 0110 905	50

NOTE: Minimum order quantity : 1000 pcs for sizes up to 7,8x365

● CABLE TIE – Colors

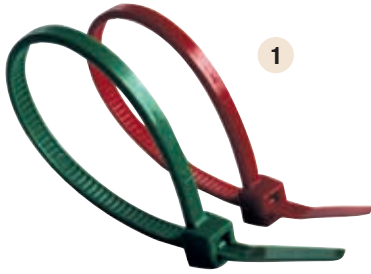

1 Colors: red, yellow, green, blue

DIMENSIONS

TECHNICAL DATA

Material: Polyamide 6.6

Dimensions	N°				
	Blue	Yellow	Red	Green	
2,5 X 98	8600340201	8600320201	8600310201	8600330201	100
3,6 X 140	8600340401	8600320401	8600310401	8600330401	100
3,6 X 200	8600340402	8600320402	8600310402	8600330402	100
4,8 X 200	8600340601	8600320601	8600310601	8600330601	100
4,8 X 290	8600340602	8600320602	8600310602	8600330602	100

● TIE MOUNT PLUG



1 Thread: M7 x 150 Ø 8 mm

DIMENSIONS

TECHNICAL DATA

Material: PA 6.6

For cable tie up to 8 mm width

Size mm	White	Black	
base 8 mm	8600701002	8600701001	100

● SCREW MOUNT & ADHESIVE PAD



DIMENSIONS

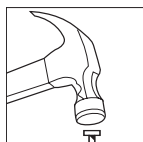

TECHNICAL DATA

Material: NYLON

Easy installation

Resistant to extreme temperatures

Size mm	White	Black	
19x19	8600911001	8600912001	100
27x27	8600911002	8600912002	100

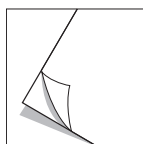

Size mm	White	Black	
19x19	8600931001	8600932001	100
27x27	8600931002	8600931002	100

● PLIERS FOR CABLE TIE PA 6.6



- 1 From 2,2-4,8 mm
- 2 From 4,8-7,8 mm

DIMENSIONS

Size mm	N°	
From 2,2-4,8	860 1000 001	1
From 4,8-7,8	860 1000 004	1

● PLIERS FOR CABLE TIE PA 6.6 and PA 12

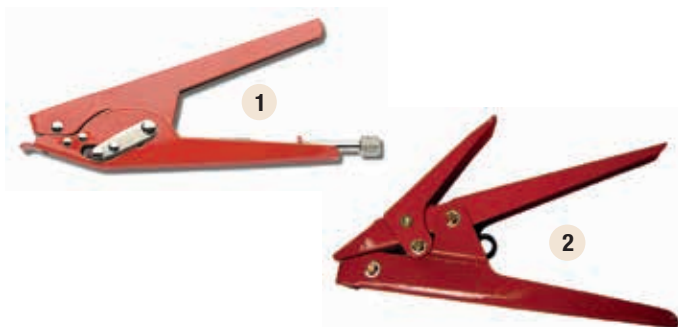

- 1 From 3,6-13 mm
- 2 From 3,6-9 mm

DIMENSIONS

Size mm	N°	
From 3,6-13	860 1000 005	1
From 3,6-9	860 1000 006	1















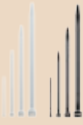

Fixing on steel structures



Solutions for secure fastening on steel structures or beam without any drilling or welding. Ideal for electrical supporting. Allows a parallel suspension at the edge of the beam. Our clips can be fastened to horizontal or vertical edges.

GUIDE FOR FIXATION ON STEEL STRUCTURES

FIXING AND ANCHORING ACCESSORIES									
		Hexagonal nut	Large washer	Threaded rod	Elevation nut	Cylindrical coupling nut	Hexagonal coupling nut	Perforated band	Cable tie
BEAM CLAMP		✓	✓	✓	✓	✓	✓	-	-
THREADED ROD HORIZONTAL CLIP		✓	✓	✓	✓	✓	✓	-	-
CABLE TIE HORIZONTAL CLIP		-	-	-	-	-	-	-	✓
PERFORATED BAND HORIZONTAL CLIP		-	-	-	-	-	-	✓	-
THREADED ROD VERTICAL CLIP		✓	✓	✓	✓	✓	✓	-	-
CABLE TIE VERTICAL CLIP		-	-	-	-	-	-	-	✓
PERFORATED BAND VERTICAL CLIP		-	-	-	-	-	-	✓	-
BEAM CLIP		-	-	-	-	-	-	-	-

● BEAM CLAMP

For sprinkler, heating, ventilation and air cooling installation



- 1 Drilled hole diameter:
7, 9, 11 and 13 mm

ADVANTAGE Unthreaded hole enable an easy and quickly assembly of threaded rod with the beam clamp.

TECHNICAL DATA

Material: cast iron; hardened steel screw; W1 nut
Hexagonal nut: DIN 439
Hexagonal bolt: DIN 933 8.8

DIMENSIONS

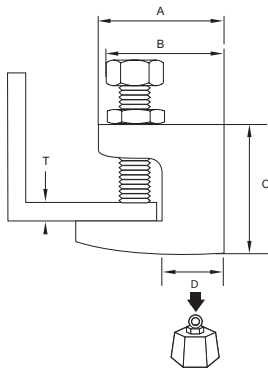

FEATURES

- Support up to max. 3500 N

D mm	T mm	A mm	B mm	C mm		N°	
7	18	38	35	35	1200	2847011007	50
9	18	38	35	35	1200	2847011009	50
11	20	44	41	42	2500	2847011011	50
13	26	58	48	54	3500	2847011013	50

● THREADED ROD HORIZONTAL CLIP

For threaded rod from M6 to M10



DIMENSIONS

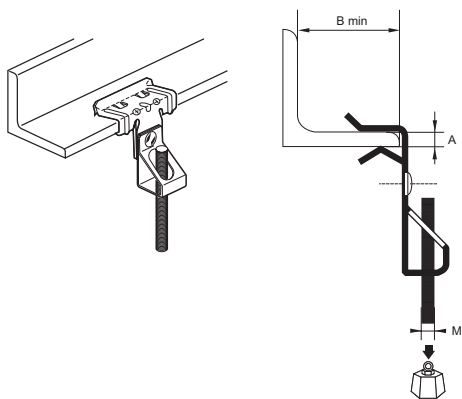



TECHNICAL DATA

Material: Steel DIN 17222

FEATURES

- Support up to max. 70 N
- For horizontal hanging on beam, thickness: 1,5 to 20 mm

A mm	B mm	M		N°	
1,5-4	18	M6	70	2847013001	100
1,5-4	18	M8	70	2847013002	100
1,5-4	18	M10	70	2847013003	100
4-10	25	M6	70	2847013004	100
4-10	25	M8	70	2847013005	100
4-10	25	M10	70	2847013006	100
10-15	25	M6	70	2847013007	100
10-15	25	M8	70	2847013008	100
10-15	25	M10	70	2847013009	100
15-20	25	M6	70	2847013010	100
15-20	25	M8	70	2847013011	100
15-20	25	M10	70	2847013012	100

● CABLE TIE HORIZONTAL CLIP



1

1 With riveted clip for cable tie hanging

DIMENSIONS

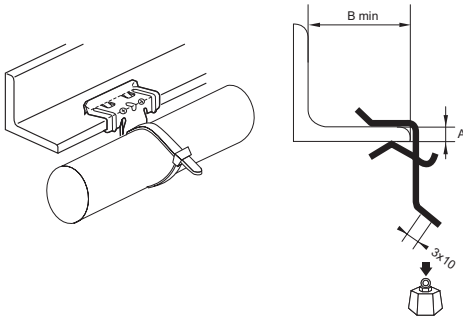



TECHNICAL DATA

Material: Steel DIN 17222

FEATURES

- Support up to max. 15 N
- For horizontal hanging on beam, thickness: 1,5 to 20 mm

A mm	B mm		N°	
1,5-4	18	15	2847014004	100
4-10	25	15	2847014010	100
10-15	25	15	2847014015	100
15-20	25	15	2847014020	100

● PERFORATED BAND HORIZONTAL CLIP



1 For perforated band up to 28 mm width

DIMENSIONS

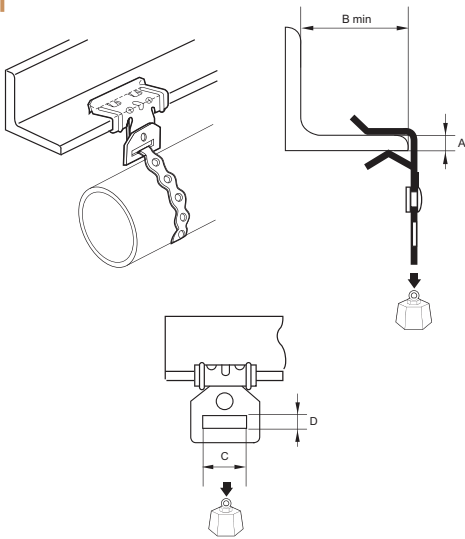



TECHNICAL DATA

Material: Steel DIN 17222

FEATURES

- Support up to max. 45 N
- For horizontal hanging on beam, thickness: 1,5 to 20 mm

A mm	B mm	CxD mm	 N	N°	
1,5-4	18	28x6,5	45	2847015004	100
4-10	25	28x6,5	45	2847015010	100
10-15	25	28x6,5	45	2847015015	100
15-20	25	28x6,5	45	2847015020	100

● THREADED ROD VERTICAL CLIP



1 For threaded rod from M6 to M10

DIMENSIONS

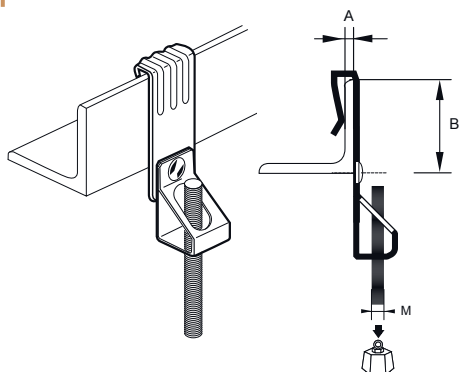



TECHNICAL DATA

Material: Steel DIN 17222

FEATURES

- Support up to max. 70 N
- For vertical hanging on beam, thickness: 1,5 to 10 mm

A mm	B mm	M		N°	
1,5-5	30	M6	70	2847022001	100
1,5-5	30	M8	70	2847022002	100
1,5-5	30	M10	70	2847022003	100
5-7	30	M6	70	2847022004	100
5-7	30	M8	70	2847022005	100
5-7	30	M10	70	2847022006	100
3-7	45	M6	70	2847022007	100
3-7	45	M8	70	2847022008	100
3-7	45	M10	70	2847022009	100
4-10	60	M6	70	2847022010	100
4-10	60	M8	70	2847022011	100
4-10	60	M10	70	2847022012	100

● CABLE TIE VERTICAL CLIP



- 1 With riveted clip for cable tie hanging

DIMENSIONS

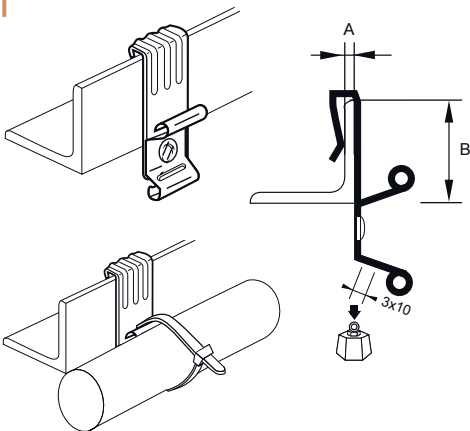



TECHNICAL DATA

Material: Steel DIN 17222

FEATURES

- Support up to max. 15 N
- For vertical hanging on beam, thickness: 1,5 to 10 mm

A mm	B mm		N°	
1,5-5	30	15	2847023001	100
5-7	30	15	2847023002	100
3-7	45	15	2847023003	100
4-10	60	15	2847023004	100

● PERFORATED BAND VERTICAL CLIP



1 For perforated band up to 28 mm width

DIMENSIONS

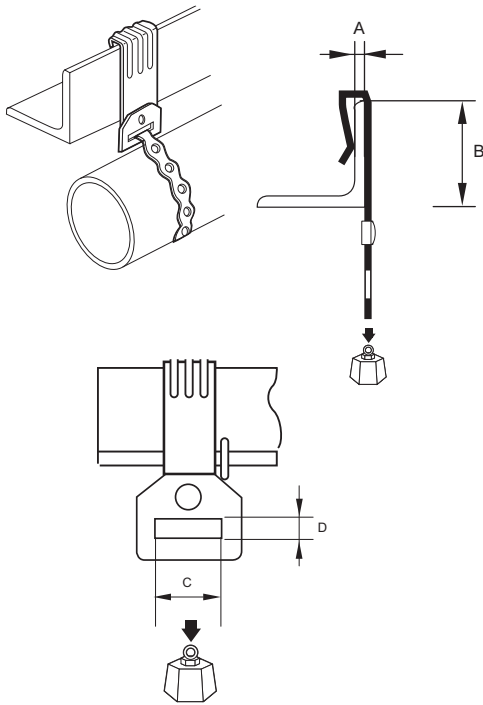



TECHNICAL DATA

Material: Steel DIN 17222

FEATURES

- Support up to max. 45 N
- For vertical hanging on beam, thickness: 1,5 to 10 mm

A mm	B mm	CxD mm		N°	
1,5-5	30	28x6,5	45	2847024001	100
5-7	30	28x6,5	45	2847024002	100
3-7	45	28x6,5	45	2847024003	100
4-10	60	28x6,5	45	2847024004	100

● BEAM CLIP

For pipe and electrical cable hanging on beam



DIMENSIONS

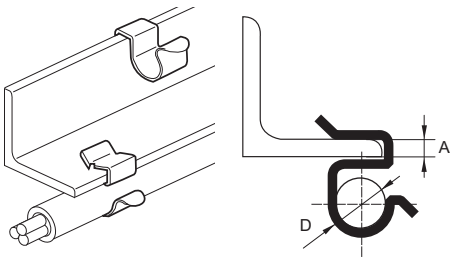

TECHNICAL DATA

Material: Steel DIN 17222

FEATURES

- For hanging on beam, thickness: 1 to 12 mm

D mm	A mm	N°	
6-7	1-4	2847031001	100
6-7	4-7,5	2847031002	100
6-7	7,5-12	2847031003	100
8-9	1-4	2847031004	100
8-9	4-7,5	2847031005	100
8-9	7,5-12	2847031006	100
10-11	1-4	2847031007	100
10-11	4-7,5	2847031008	100
10-11	7,5-12	2847031009	100
12-14	1-4	2847031010	100
12-14	4-7,5	2847031011	100
12-14	7,5-12	2847031012	100
15-18	1-4	2847031013	100
15-18	4-7,5	2847031014	100
15-18	7,5-12	2847031015	100
19-24	1-4	2847031016	100
19-24	4-7,5	2847031017	100
19-24	7,5-12	2847031018	100
25-30	1-4	2847031019	100
25-30	4-7,5	2847031020	100
25-30	7,5-12	2847031021	100



Stainless Steel Supporting and Fixing



Our stainless steel products have a better resistance to corrosion, oxidation and moisture. They are mainly used in the field of piping, chemical industry, petrochemical and agri-food.

● STAINLESS STEEL PIPE CLAMP M8/M10 WITH CAPTIVE SCREWS

For ventilation and aeraulics



- 1 M8/M10 nut
- 2 2 unloss M6 screws with plastic washers
- 3 Band thickness: 2 mm

ADVANTAGE Plastic washers avoid the loss of side screws.

TECHNICAL DATA

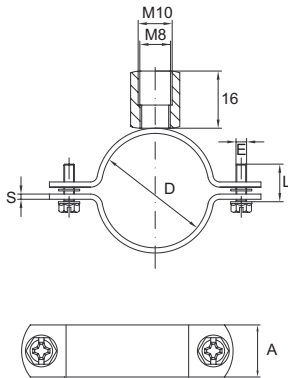

Material: W5 (W1 available)

DIMENSIONS



FEATURES

- Support up to max. 2000 N

D (min-max) mm	D "	A mm	S mm	E mm	L mm		N°	
5-18	3/8"	20	2,0	M6	15	2000	2857011018	50
0-24	1/2"	20	2,0	M6	15	2000	2857011022	50
6-30	3/4"	20	2,0	M6	15	2000	2857011028	50
2-36	1"	20	2,0	M6	15	2000	2857011035	50
6-42	1 1/4"	20	2,0	M6	20	2000	2857011040	25
47-50	1 1/2"	20	2,0	M6	20	2000	2857011048	25
51-55	-	20	2,0	M6	20	2000	2857011054	25
60-64	2"	20	2,0	M6	20	2000	2857011060	25
67-73	-	20	2,0	M6	20	2000	2857011070	25
75-80	2 1/2"	20	2,0	M6	20	2000	2857011075	25
82-90	3"	20	2,0	M6	20	2000	2857011090	25
100-103	3 1/2"	20	2,0	M6	20	2000	2857011100	25
106-112	-	20	2,0	M6	20	2000	2857011110	25
114-119	4"	20	2,0	M6	26	2000	2857011115	25
124-131	-	20	2,0	M6	26	2000	2857011125	25
133-140	5"	20	2,0	M6	26	2000	2857011140	25
159-163	6"	20	2,0	M6	26	2000	2857011160	25
199-204	-	20	2,0	M6	26	2000	2857011200	25
215-225	8"	20	2,0	M6	26	2000	2857011220	25

● STAINLESS STEEL CHANNEL 28/30 C-SHAPE

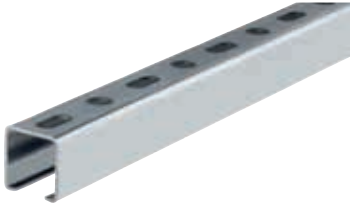

DIMENSIONS

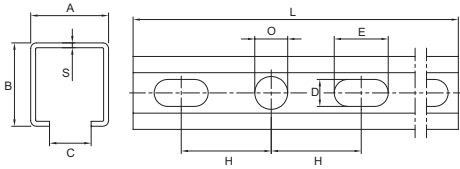

TECHNICAL DATA

Material: W4 / A2

Length: 2000 mm, thickness: 1,80 mm

A mm	B mm	S mm	C mm	D mm	E mm	H mm	O mm	L mm	N°	
28	30	1,8	15	10	20	35	12	2000	2857032028	12

● STAINLESS STEEL CHANNEL 38/40 C-SHAPE

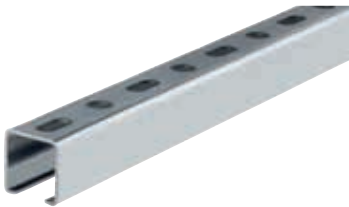

DIMENSIONS

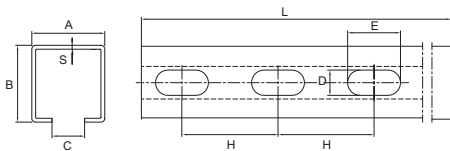

TECHNICAL DATA

Material: W4 / A2

Length: 2000 mm, thickness: 2,00 mm

A mm	B mm	S mm	C mm	D mm	E mm	H mm	L mm	N°	
38	40	2	17	13,2	27,5	50	2000	2857033038	12

● STAINLESS STEEL CHANNEL SCREW FOR C-SHAPE CHANNEL



DIMENSIONS

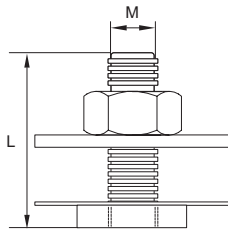

TECHNICAL DATA

Material: W4 / A2

FEATURES

- Allow quick installation on C-Shape channels
- Quick positioning after installation due to the fixing mechanism, with free longitudinal movement in the channel

Rail type	M	L mm	⊙ mm	N°	
27/18-28/30	M8	30	8x24	2857041830	100
27/18-28/30	M10	30	10x30	2857041930	100
38/40	M8	30	8x24	2857042830	100
38/40	M10	30	10x30	2857042930	100

● STAINLESS STEEL FIXING PLATE FOR C-SHAPE CHANNEL



- 1 45° Fixing plate
- 2 90° Fixing plate
- 3 0° Fixing plate

DIMENSIONS

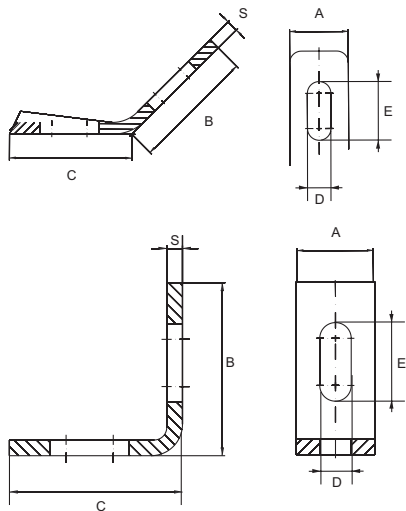

TECHNICAL DATA

Material: W4 / A2

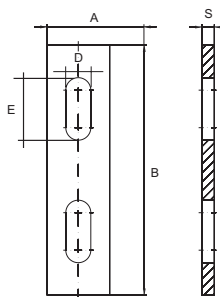

Tilt °	A mm	B mm	C mm	S mm	DxE mm	N°	
45°	25	52	52	5	25x10	2857044045	100
90°	25	55	55	5	25x10	2857044090	100
0°	25	100	-	5	25x10	2857045000	100

● STAINLESS STEEL DOUBLE THREADED SCREW



- 1 Torx footprint  enables an easy tightening with a better torque transmission
- 2 Hexagonal shape for easy tightening

DIMENSIONS

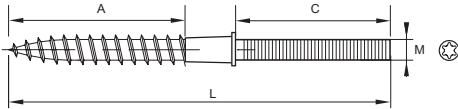

TECHNICAL DATA

Material: W4 / A2

M	L	A	C	N°	
M8	50	30	10	2857072850	100
M8	90	40	40	2857072890	100
M10	60	-	-	2857072108	100
M10	90	-	-	2857072109	100

● STAINLESS STEEL HEXAGONAL NUT



DIMENSIONS

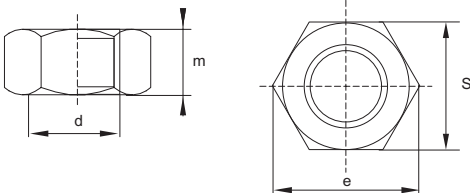

TECHNICAL DATA

Material: W4 / A2
Class 8 – DIN 934

d	DIN	m mm	S mm	e mm	N°	
M8	934	6,5	13	14,3	2857081008	100
M10	934	8	16	18,9	2857081010	100

● STAINLESS STEEL LARGE WASHER



DIMENSIONS

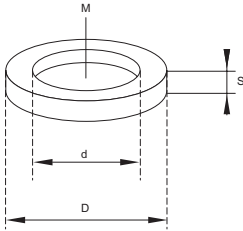

TECHNICAL DATA

Material: W4 / A2
DIN 9021

M	D mm	d mm	S mm	N°	
M8	24	8,4	2	2857082008	100
M10	30	10,5	2,5	2857082010	100

● STAINLESS STEEL THREADED ROD



DIMENSIONS

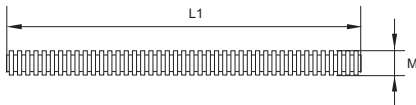

TECHNICAL DATA

Material: W4 / A2
DIN 975

M	L1 mm	N°	
M8	1000	2857101008	50
M10	1000	2857101010	25

● STAINLESS STEEL RECTANGULAR BASE PLATE

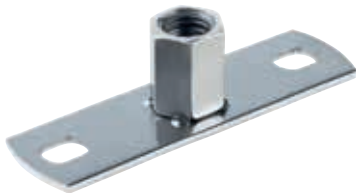

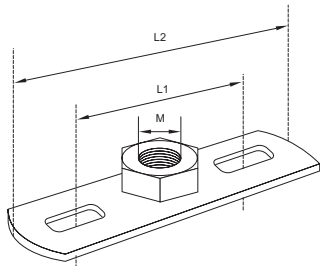

DIMENSIONS



TECHNICAL DATA

Material: W5 / A4
M8/M10 nut

M	L1 mm	L2 mm	N°		N°	
M8/M10	50	80	2857105030	100	2856105030	1000

● STAINLESS STEEL BAND

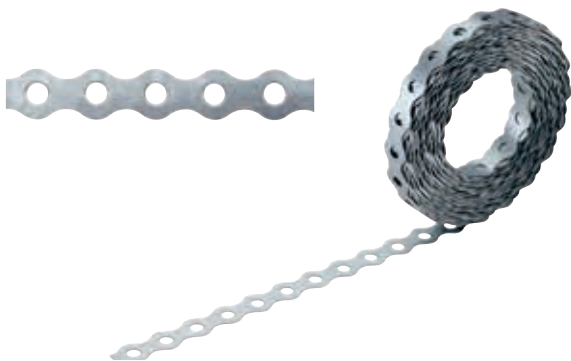

DIMENSIONS

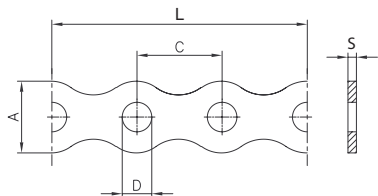



TECHNICAL DATA

Material: W4 / A2

L m	A mm	S mm	C mm	D mm	N°	
10	12	0,8	14,5	5	2857111012	10
10	17	0,8	20,2	7	2857111017	10
10	26	1	25	8	2857111026	10

TECHNICAL INFORMATION

FIXING ON STEEL SYMBOLS

	Decibel reduction
	Maximum load allowed in Newton
	Maximum load allowed in Kilograms
	Small packaging
	Torx footprint
	Strut 41 Profile
	To nail
	Self-adhesive

THE NEWTON FORCE CONCEPT

Newton (**N**) force is part of the International System of Units (SI). It is defined as force (**F**) necessarily to apply acceleration (**a**) of 1m/s^2 to an object of mass (**m**) of 1kg. The acceleration is a quantity vector, i.e. a value defined by a magnitude and a direction. Therefore the force is also a quantity vector. It is defined by the mathematical formula:

$$F = m \times a \qquad [N = \text{kg} \times \text{m/s}^2]$$

Doing calculations, the fact that the Earth attracts any mass with a nearly constant acceleration defined as (**g**) must be considered. It's value varies slightly due to the height and latitude. Gravity is represented as:

$$a = g = 9.81 \qquad [\text{m/s}^2]$$

When a system's mass is constant, i.e. there is no acceleration or deceleration that may be applied to the media due to cause a change of direction or a decrease in flow. The calculation to determine the mass shall be:

$$m = F / 9.81 \qquad [\text{kg} = \text{N/s}^2]$$

Example of calculation: A pipe clamp can withstand a maximum force of 490N. To determine the maximum weight in kg that can be attached, the following calculation must be done:

$$m = 490/9,81 = 50 \quad [\text{kg} = \text{N/s}^2]$$

Knowing the maximum weight in kg that the pipe clamp can withstand, the equivalent force can be found by a reciprocal calculation:

$$F = 50 \times 9,81 = 490 \quad [\text{N} = \text{kg} \times \text{m/s}^2]$$

In our catalogue we indicated the maximum force that our fasteners can withstand. If there are changings in the acceleration (increase or decrease) of the fluid inside the installation, the mass must be recalculated.

Recommendation:

To prevent system failures, it is not allowed to exceed the specified maximum strength.

Technical Recommendations:

In general, for sanitary installations, we recommend using our isophonic EPDM pipe clamps, which offer better protection against noise and vibration.



For gas installations, we recommend isophonic and plastic pipe clamps.
For corrosive environments, we recommend stainless steel pipe clamps.

Installation Tips:



Generally, the space between two clamps is 0.5 meters to 2 meters. The weight of the medium inside a pipe must be considered because of respecting the maximum permissible load, referring to the load it bears and the clamp used model. It is therefore recommended to take into account the clamp's safety coefficients.

Never tighten a clamp with an inappropriate tools because the pipe clamp safety factor may be overtaken and cause damages to the clamp. In general, a manual tightening of the clamp is enough. In case of doubt in the installation, consult our technical department who will answer your questions.



STEEL TUBES DIN 2448

		Pipe weight	Internal volume	Water filled pipe
[mm]	[mm]	Kg/m	[l/m]	Kg/m
13,5	1,8	0,522	0,077	0,599
16	1,8	0,632	0,121	0,753
17,2	1,8	0,688	0,145	0,833
20	2	0,89	0,201	1,091
21,3	2	0,962	0,235	1,197
25	2	1,13	0,346	1,476
26,9	2,3	1,41	0,39	1,8
30	2,6	1,77	0,483	2,253
31,8	2,6	1,88	0,555	2,435
33,7	2,6	2,01	0,638	2,648
38	2,6	2,29	0,845	3,135
42,4	2,6	2,57	1,086	3,656
44,5	2,6	2,7	1,212	3,912
48,3	2,6	2,95	1,458	4,408
51	2,6	3,12	1,647	4,767
57	2,9	3,9	2,058	5,958
60,3	2,9	4,41	2,332	6,472
63,5	2,9	4,36	2,614	6,974
70	2,9	4,83	3,235	8,065
76,1	2,9	5,28	3,88	9,16
82,5	3,2	6,31	4,546	10,856
88,9	3,2	6,81	5,343	12,153
101,6	3,6	8,76	6,995	15,755
108	3,6	9,33	7,976	17,306
114,3	3,6	9,9	9,004	18,904
127	4	12,2	11,116	23,316
133	4	12,8	12,266	25,066
139,7	4	13,5	13,616	27,116
152,4	4,5	16,4	16,142	32,542
159	4,5	17,1	17,663	34,763
165,1	4,5	17,8	19,128	36,928
168,3	4,5	18,1	19,921	38,021
177,8	5	21,3	22,103	43,403
193,7	5,4	25	26,26	51,26
219,1	5,9	31	33,734	64,734
244,5	6,3	37,1	42,215	79,315
267	6,3	40,6	50,805	91,405



STEEL TUBES DIN 2440

Nominal diameter			Pipe weight	Internal volume	Water filled pipe
["]	[mm]	[mm]	Kg/m	[l/m]	Kg/m
1/4"	13,5	2,35	0,68	0,061	0,74
3/8"	17,2	2,35	0,89	0,123	1,013
1/2"	21,3	2,65	1,27	0,201	1,471
3/4"	26,9	2,65	1,65	0,366	2,016
1"	33,7	3,25	2,55	0,581	3,131
1.1/4"	42,4	3,25	3,28	1,012	4,292
1.1/2"	48,3	3,25	3,77	1,372	5,142
2"	60,3	3,65	5,33	2,205	7,535
2.1/2"	76,1	3,65	6,8	3,716	10,516
3"	88,9	4,05	8,85	5,125	13,975
4"	114,3	4,5	12,6	8,704	21,304
5"	139,7	4,85	16,9	13,267	30,167
6"	165,1	4,85	20,1	18,958	39,057



GA TUBES DIN 19500

Nominal diameter			Pipe weight	Internal volume	Water filled pipe
[mm]	[mm]	[mm]	Kg/m	[l/m]	Kg/m
50	60	3,5	5,3	2,205	7,505
70	80	3,5	7,1	4,183	11,283
100	112	4	10,3	8,491	18,791
125	137	4	13,7	13,063	26,763
150	162	5	17,3	18,137	35,437
200	212	6	32,7	31,4	64,1



TUBES DIN 1786 & 1754

		Pipe weight	Internal volume	Water filled pipe
[mm]	[mm]	Kg/m	[l/m]	Kg/m
10	1	0,252	0,05	0,302
12	1	0,308	0,07	0,387
15	1	0,391	0,133	0,524
18	1	0,475	0,201	0,676
22	1	0,587	0,314	0,901
22	1,5	0,86	0,283	1,143
28	1,5	1,11	0,491	1,601
35	1,5	1,41	0,804	2,214
42	1,5	1,7	1,194	2,894
54	2	2,91	1,963	4,873
64	2	3,47	2,826	6,296
70	2	3,8	3,419	7,219
76,1	2	4,14	4,081	8,221
88,9	2	4,87	5,658	10,528
10,8	2,5	7,38	8,328	25,708
133	3	10,9	12,261	23,561
159	3	13,1	18,376	31,476
219	3	18,1	35,615	53,715
267	3	22,1	53,475	75,771



PE TUBES (sebem7)

Nominal diameter [mm]			Pipe weight Kg/m	Internal volume [l/m]	Water filled pipe Kg/m
26	32	3	0,273	0,531	0,804
34	40	3	0,348	0,907	1,255
40	50	3	0,443	1,52	1,963
50	56	3	0,5	1,963	2,463
57	63	3	0,566	2,55	3,116
70	75	3	0,679	3,737	4,416
80	90	3,5	0,952	5,408	6,36
100	110	4,3	1,432	8,071	9,503
125	125	4,9	1,817	10,454	12,271
150	160	6,2	3,004	17,102	20,106
200	200	6,2	3,83	27,627	31,457
250	250	7,8	6,019	43,131	49,15
300	315	9,9	9,655	68,535	78,19

SML TUBES

Nominal diameter [mm]			Pipe weight Kg/m	Internal volume [l/m]	Water filled pipe Kg/m
50	58	3,5	4,3	2,1	6,4
70	78	3,5	5,9	4	9,9
100	110	3,5	8,4	9,3	17,7
125	135	4	11,8	12,7	24,5
150	160	4	14,1	18,2	32,3
200	210	5	23,1	33,5	56,6
250	274	5,5	33,3	54,4	87,7
300	326	6	43,2	77,6	120,8

PVC TUBES

Nominal diameter [mm]			Pipe weight Kg/m	Internal volume [l/m]	Water filled pipe Kg/m
40	50	1,8	0,244	1,04	1,284
50	63	1,8	0,308	1,69	1,998
70	75	1,9	0,49	3,44	3,93
100	110	2,7	1,025	6,981	8,006
125	125	3,1	1,351	11,079	12,43
150	160	3,9	2,158	15,873	18,031

MATERIALS USED: RAW MATERIAL

Steel:

We use hot rolled carbon steel according to European standard EN 10051 to manufacture our steel clamps.

Stainless steel:

The stainless steel clamps are made of AISI 316 (1.4401)/A4, the profiles and some accessories of AISI 304 (1.4301)/A2.

The AISI 304 steel includes a basic anti-corrosive grade. This allows good resistance to atmospheric corrosion, neutral wet environments, alkaline corrosion, non-chlorinated nor sulphuric acidic environments. The main applications are piping and heat exchangers for the chemical, cryogenic petrochemical and boiler fabrication industries, food industries, construction and decoration. The AISI 316 steel contains Molybdenum allowing better reaction to chlorinated wet environments than AISI 304 steel. The main applications are piping for tubular heat exchangers in the chemical, petrochemical, sheet metal work and food industries.

COATINGS

Zinc:

Metal clamps have anticorrosive protection made with an applied electrolytic zinc coating.

Plastic:

The plastic clamps are coated with Polyamide 11 or Rilsan.

Technical characteristic: Solidity/Hardness Shore D ASTM D2240: Shore 75, Electrical insulation: 25-38Kv/mm. Resistance to salt fog, no corrosion point after 2000 hours of exposure (ASTM B-117 or AENOR X 41-002). Resistance to seawater, no corrosion after 6 years of exposure.

Sendzimir galvanized:

Channels and accessories with Sendzimir galvanized finishing are covered with a layer of zinc, according to the specifics provided by the material supplier. Galvanization according to EN 10327: continuously hot dip coating for low carbon strips and sheets for cold forming.

Hot dip galvanized:

Channels and accessories are coated with a layer of zinc of at least 395 g/m². Hot dip galvanized according to UNE:EN ISO 1461: 1999 for various parts.

DACROMET

The rails and accessories have a Dacromet finish that has an excellent coating composed of zinc and aluminium strips in a matrix of chromium oxide.

Salt testing (Grade B) over 1000 hours without red oxide. Without the formation of white oxide (zinc corrosion) before 250 hours.

SPECIAL PLASTIC

Polyamide 11, a protective cover that acts like a true thermoplastic free solvent and catalyst agents.

What is polyamide?

Polyamide 11 is a corrosion protective coating, with a powdered texture, that provides protection in the equipment used in the water industry.

This material (polyamide 11) was subjected to tests conducted by different international organizations such as EEUU, Europe and Asia, with the aim of satisfying the basic rules of system protection against corrosion and the following complement of requirements:

- Not toxic
- Protect equipment from corrosion in all its aspects (bacteria, formation of tubercles)
- Have flexibility and resistance to impact and erosion supporting UV rays and weathering
- Can be repaired on the spot and simple to use.

What are the benefits of a special finishing plastic polyamide 11?

- Excellent corrosion, wear and abrasion resistance.
- Excellent resistance to water and ice.
- Electrical insulation and unique combination of materials for long-term protection.
- Low coefficient of friction and high resistance to impact.
- Prevents bacteria from adhering and approval for contact with food.
- Very good service life when facing multiple conditions.
- Compared to other painted plastics, the higher cost is due to a 700% greater service life, which in the long-term returns a lower cost.
- It is a product made from plant material, which explains why its price does not depend on the availability of mineral and petroleum oils or other materials.

MATERIALS

Standard Gum

Elastomer base	EPDM
Colour	Black
Density	1.32 g/cm ³
Hardness	45 Shore D
Sound reduction	18 db(A), DIN 4109
Tensile strength	91 kg/cm ²
Stretch	440%
Tear resistance	S/ASTM D-624 Type C, I: 24,9 Kg/cm
Resistance to external agents	Excellent
Resistance to ozone	Grade 0
Temperature resistance	-40°C / + 110°C
Fire resistance	Class B2 (DIN 4102)
UV resistance	Excellent

Polyurethane with lateral rubber

Pipe supports are made of PUR in the central part, and comprises 2 parts of rubber on each side. The whole part is coated with a black vapour barrier.

Temperature resistance	-45°C / + 105°C
Thermal conductivity	0.036 W(m.K) at 0°C.
Density	80 Kg/m ³
Storage Temperature	-10°C / +30°C
Colour	Black
Water steam resistance factor	>7000
Compressive strength	850 (+/-200)
Tensile strength	550 (+/-50)

Polyurethane with aluminium

Pipe supports are made of PUR; covered with a vapour barrier with a strap made of two layers of aluminium and a layer of polyester.

Temperature resistance	-40°C / +80°C
Thermal conductivity	0.030 W(m.K) at 0°C.
Density	80 (+/-8) Kg/m ³
Colour	PUR: salmon
Compressive strength	1000 (+/-2000)
Tensile strength	550 (+/-50)

PROFILE SELECTION

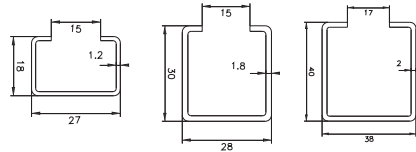
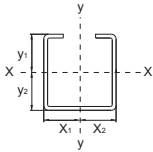

Dimensions		27/18	28/30	38/40
Thickness	(mm)	1,2	1,8	2
Area	A (mm ²)	69,28	144,02	232,3
Weight	(Kg/m)	0,551	1,075	1,844
Length	(m)	2	2	2/3/6
Material				
Allowed maximum load	σ (N/mm ²)	160	160	160
Allowed maximum deflection	L/150	L/150	L/150	L/150
Mechanical performance				
Axis x-x				
Distance 1 to centre of gravity	Y ₁ (mm)	9,45	15,53	20,62
Distance 2 to center of gravity	Y ₂ (mm)	8,55	14,47	19,38
Moment of inertia x-x	I _{x-x} (cm ⁴)	0,29	1,52	4,73
Modulus of resistance	W _{x-x} (cm ³)	0,31	0,98	2,29
Gyration radius	ρ (cm)	0,65	1,03	1,43
Maximum bending moment	M (Nxm)	48,98	156,4	367,1
Axis y-y				
Distance 1 to centre of gravity	X ₁ (mm)	13,5	14	19
Distance 2 to center of gravity	X ₂ (mm)	13,5	14	19
Moment of inertia y-y	I _{y-y} (cm ⁴)	0,94	2,16	6,27
Modulus of resistance	W _{y-y} (cm ³)	0,7	1,54	3,3

- The attached table can be used as an approximation for profile cases, for which the load would be concentrated and centred. In other cases, such as a more or less uniform load dispersion, considering the sum of all loads, you can use as orientation the load applied to the centre of the profile.
- In the table, the maximum longitude is indicated by the letter (**L**), which may have a profile as a function of the load being supported (**F**). Column “f” represents the deflection that occurs in these load conditions.
- For the calculations, the maximum steel tension considered is **s'F3=160N/mm²** and the maximum deflection allowed **f=L/150** (the deflection limits the profile length when it is detached with respect to its other dimensions).

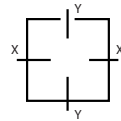

Profile	Weight	Area	Inertia		Resistance	
	Kg/m	cm ²	cm ⁴	cm ⁴	cm ³	cm ³
27/18	0,551	0,69	0,29	0,94	0,31	0,7
28/30	1,075	1,44	1,52	2,16	0,98	1,54
38/40	1,844	2,32	4,73	6,27	2,29	3,3

Test carried out in Laboratories LGAI Technological Center S.A.

F(kN)	27/18		28/30		38/40	
	L (cm)	f (mm)	L (cm)	f (mm)	L (cm)	f (mm)
0,1	140	9,3	320	21,4	565	37,7
0,15	114	7,6	261	17,4	461	30,8
0,2	98	6,4	226	15,1	399	26,6
0,25	78	4,1	202	13,5	357	23,8
0,3	65	2,9	184	12,3	326	21,7
0,4	49	1,6	156	10	282	18,8
0,5	39	1	125	6,4	252	16,8
0,75	26	0,5	83	2,8	196	11,8
1	20	0,3	63	1,6	147	6,6
1,25	16	0,2	50	1	117	4,2
1,5	13	0,1	42	0,7	98	3
1,75	11	0,1	36	0,5	84	2,2
2	10	0,1	31	0,4	73	1,7
2,25	9	0,1	28	0,3	65	1,3
2,5	8	N.A	25	0,3	59	1,1
2,75	7	N.A	23	0,2	53	0,9
3	7	N.A	21	0,2	49	0,7
3,5	6	N.A	18	0,1	42	0,5
4	5	N.A	16	0,1	37	0,4

Load "F" can go in one up or down direction because the table is calculated by taking into account the worst case.

N.A : Not Applicable = non applicable

PROFILE SELECTION

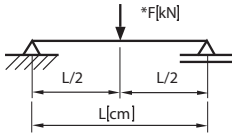

Unit Conversion:

$$1 \text{ Kg} = 1 \text{ Kp} = 9,8 \text{ N} = 10 \text{ N}$$

$$1 \text{ KN} = 1000 \text{ N} = 100 \text{ Kg} = 100 \text{ Kp}$$

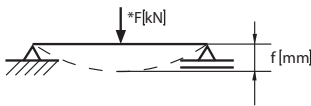

Profile

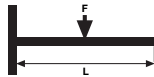

L=	0,5 m	1 m	1,5 m	2 m
27/18	358 N	179 N	87 N	49 N
28/30	1254 N	627 N	418 N	281 N
38/40	3002 N	1501 N	1001 N	750 N

Profile

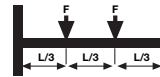

L=	0,5 m	1 m	1,5 m	2 m
27/18	269 N	126 N	51 N	29 N
28/30	941 N	442 N	293 N	165 N
38/40	2251 N	1057 N	750 N	527 N

Profile

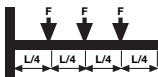

L=	0,5 m	1 m	1,5 m	2 m
27/18	179 N	82 N	36 N	21 N
28/30	627 N	314 N	209 N	118 N
38/40	1501 N	750 N	500 N	375 N

Profile

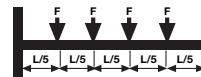

L=	0,5 m	1 m	1,5 m	2 m
27/18	149 N	62 N	28 N	16 N
28/30	521 N	260 N	160 N	90 N
38/40	1246 N	623 N	415 N	288 N

Maximum load calculations are based on following datas:

Maximum material stress for steel < 160 N/mm² . Allowed maximum deflection f=L/150.

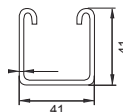
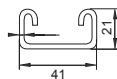
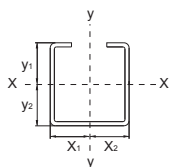

Dimensions		41/21			41/41		
Thickness	(mm)	1,5	2	2,5	1,5	2	2,5
Area	A (mm ²)	124,3	161,97	197,3	187,2	241,9	297,3
Weight	(Kg/m)	0,98	1,31	1,63	1,45	1,93	2,41
Lenght	(m)	3 à 6	3 à 6	3 à 6	3 à 6	3 à 6	3 à 6
Material							
Allowed maximum load	σ (N/mm ²)	160	160	160	160	160	160
Allowed maximum deflection	L/150	L/150	L/151	L/152	L/154	L/155	L/156
Mechanical performance							
Axis x-x							
Distance 1 to centre of gravity	Y ₁ (mm)	11,27	11,3	11,33	20,94	21,25	21,32
Distance 2 to center of gravity	Y ₂ (mm)	9,73	9,7	9,67	20,06	19,75	19,68
Moment of inertia x-x	I _{x-x} (cm ⁴)	0,7	0,87	1,01	3,95	4,94	5,92
Modulus of resistance	W _{x-x} (cm ³)	0,62	0,77	0,89	1,88	2,32	2,78
Gyration radius	ρ (cm)	0,75	0,73	0,72	1,45	1,43	1,41
Maximum bending moment	M (Nxm)	99,38	123,19	143,09	301,43	371,95	444,13
Axis y-y							
Distance 1 to centre of gravity	X ₁ (mm)	20,5	20,5	20,5	20,5	20,5	20,5
Distance 2 to center of gravity	X ₂ (mm)	20,5	20,5	20,5	20,5	20,5	20,5
Moment of inertia y-y	I _{y-y} (cm ⁴)	3,45	4,41	5,28	5,78	6,78	8,99
Modulus of resistance	W _{y-y} (cm ³)	1,68	2,15	2,58	2,82	3,31	4,39

PROFILE SELECTION

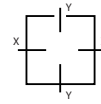

Profile	Weight	Section	Inertia		Resistance	
	Kg/m	cm ²	cm ⁴	cm ⁴	cm ³	cm ³
41/21	1,63	1,97	1,01	5,28	0,89	2,58
41/41	2,41	2,97	5,92	8,99	2,78	4,39

Test carried out in Laboratories LGAI Technological Center S.A.

- The attached table can be used as an approximation for profile cases, for which the load would be concentrated and centred. In other cases, such as a more or less uniform load dispersion, considering the sum of all loads, you can use as orientation the load applied to the centre of the profile.
- In the table, the maximum longitude is indicated by the letter (**L**), which may have a profile as a function of the load being supported (**F**). Column “**f**” represents the deflection that occurs in these load conditions.
- For the calculations, the maximum steel tension considered is **s’F3=160N/mm²** and the maximum deflection allowed **f=L/150** (the deflection limits the profile length when it is detached with respect to its other dimensions).

F (kN)	41/21 (1,5)		41/21 (2,0)		41/21 (2,5)		41/41 (1,5)		41/41 (2,0)		41/41 (2,5)	
	L (cm)	f (mm)	L (cm)	f (mm)	L (cm)	f (mm)	L (cm)	f (mm)	L (cm)	f (mm)	L (cm)	f (mm)
0,25	137	9,2	153	10,2	165	11	326	21,7	365	24,3	399	26,7
0,5	80	3,6	99	5,5	114	7,3	230	15,4	258	17,2	282	18,8
0,75	53	1,6	66	2,4	76	3,3	161	7,8	198	11,8	230	15,4
1	40	0,9	49	1,4	57	1,8	121	4,4	149	6,6	178	9,4
1,25	32	0,6	39	0,9	46	1,2	96	2,8	119	4,2	142	6
1,5	27	0,4	33	0,6	38	0,8	80	2	99	2,9	118	4,2
1,75	23	0,3	28	0,4	33	0,6	69	1,4	85	2,2	102	3,1
2	20	0,2	25	0,3	29	0,5	60	1,1	74	1,7	89	2,3
2,25	18	0,2	22	0,3	25	0,4	54	0,9	66	1,3	79	1,9
2,5	16	0,1	20	0,2	23	0,3	48	0,7	60	1,1	71	1,5
2,75	14	0,1	18	0,2	21	0,2	44	0,6	54	0,9	65	1,2
3	13	0,1	16	0,2	19	0,2	40	0,5	50	0,7	59	1
3,5	11	0,1	14	0,1	16	0,1	34	0,4	43	0,5	51	0,8
4	10	0,1	12	0,1	14	0,1	30	0,3	37	0,4	44	0,6
4,5	9	N.A	11	0,1	13	0,1	27	0,2	33	0,3	39	0,5
5	8	N.A	10	0,1	11	0,1	24	0,2	30	0,3	36	0,4
6	7	N.A	8	N.A	10	0,1	20	0,1	25	0,2	30	0,3
7	6	N.A	7	N.A	8	N.A	17	0,1	21	0,1	25	0,2
8	5	N.A	6	N.A	7	N.A	15	0,1	19	0,1	22	0,1

Load “F” can go in one up or down direction because the table is calculated by taking into account the worst case.

NA = Not Applicable

PROFILE SELECTION

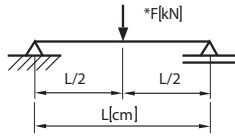

Unit Conversion:

$$1 \text{ Kg} = 1 \text{ Kp} = 9,8 \text{ N} = 10 \text{ N}$$

$$1 \text{ KN} = 1000 \text{ N} = 100 \text{ Kg} = 100 \text{ Kp}$$

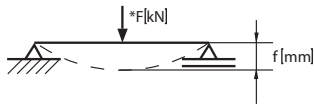

Profil

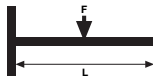

L=	0,5 m	1 m	1,5 m	2 m	2,5 m	3 m
41/21	1 100 N	550 N	300 N	170 N	80 N	50 N
41/41	3 400 N	1 700 N	1 150 N	850 N	500 N	300 N

Profil

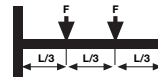

L=	0,5 m	1 m	1,5 m	2 m	2,5 m	3 m
41/21	800 N	400 N	175 N	95 N	45 N	30 N
41/41	2 500 N	1 300 N	850 N	575 N	300 N	200 N

Profil

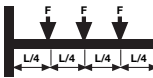

L=	0,5 m	1 m	1,5 m	2 m	2,5 m	3 m
41/21	550 N	275 N	120 N	70 N	30 N	20 N
41/41	1 700 N	850 N	550 N	410 N	230 N	160 N



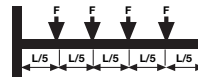

Profil

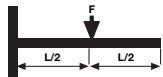
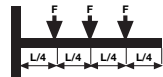
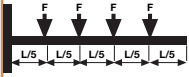

L=	0,5 m	1 m	1,5 m	2 m	2,5 m	3 m
41/21	450 N	230 N	100 N	50 N	23 N	16 N
41/41	1 400 N	700 N	460 N	320 N	180 N	120 N

Maximum load calculations are based on following datas:

Maximum material stress for steel $< 160 \text{ N/mm}^2$. Allowed maximum deflection $f=L/150$.

Support	Length				
 27/18	200 mm	214 N	429 N	214 N	143 N
	300 mm	135 N	270 N	135 N	90 N
 38/40	200 mm	1 606 N	3 212 N	1606 N	1 071 N
	250 mm	1 285 N	2 570 N	1285 N	857 N
	300 mm	1 071 N	2 141 N	1 071 N	714 N
	350 mm	908 N	1 835 N	918 N	612 N
	400 mm	803 N	1 606 N	803 N	535 N
	500 mm	642 N	1 285 N	642 N	428 N
	600 mm	535 N	1 071 N	535 N	357 N
	1000 mm	199 N	397 N	199 N	132 N
 41/21	150 mm	954 N	1 908 N	954 N	636 N
	300 mm	473 N	946 N	473 N	315 N
	450 mm	210 N	420 N	210 N	140 N
 41/41	150 mm	2 961 N	5 922 N	2 961 N	1 974 N
	250 mm	1 777 N	3 553 N	1 777 N	1 184 N
	300 mm	1 480 N	2 961 N	1 480 N	987 N
	350 mm	1 269 N	2 538 N	1 269 N	846 N
	450 mm	987 N	1 974 N	987 N	658 N
	550 mm	808 N	1 615 N	808 N	538 N
	600 mm	690 N	1 381 N	690 N	460 N
	650 mm	588 N	1 177 N	588 N	392 N
	750 mm	442 N	884 N	442 N	295 N
	1000 mm	249 N	497 N	249 N	166 N

Maximum load calculations are based on following datas:

Maximum material stress for steel < 160 N/mm² . Allowed maximum deflection $f=L/150$.

FIXING ON STEEL STRUCTURES

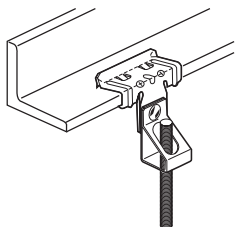

Quick fasteners are the ideal solution for the union of metal or concrete structures with other elements: cables, tubes, plates, clamps, suspended ceilings, etc. They are characterized by the following advantages:

Speed: The assembly produces genuine time and money savings for installers.

Wide range: Parts combined to best suit any need.

Safety and convenience: It is not necessary to pierce the metal structure.

Finishing: All fastening elements are covered with an anti-corrosive layer.

Directions for use: Installation of fasteners is quick and easy. In most cases, a simple hammer is enough.

Application loads: The fastening elements are tested and checked; a safety factor of 3 is applied. Load values expressed are interpreted as limits for static loads applied vertically to the structure or installation.

When fasteners are combined with each other, the load value is determined by the element whose capacity is lowest.

If the structure on which the fastener is placed has a load value less than that of the fastener, it will determine the maximum load value to be applied.

Material used: Carbon steel for springs according to DIN 17222 (UNE-EN 10132-4). After heat treating and tempering, steel acquires a hardness of HRc 43/50.

CORROSION PROTECTION

Zinc phosphating

For indoor and non-corrosive environments: Corrosion protection with joint impregnation with rust inhibiting oil.

Finishing

For interior, exterior, wet or slightly corrosive atmospheres:

- Non-hydrogenating coating (without electrolysis or acidic stripping)
- Electrical conductivity. High temperature resistance.
- Without chromium VI nor chromium III. Reduced friction values.
- High protection against corrosion. Cathodic protection.
- Optical: Gray – Silver

RESISTANCE to corrosion in salt spray chamber up to 480 h (DIN 50021).

NOTE: Thanks to industrial improvements, NORMA Group reserves the right to modify the design of the fasteners shown while respecting the static load characteristics.



NORMA GROUP ADDITIONAL **SOLUTIONS AND DEVELOPMENT**

NORMA GROUP, as a global supplier, offers a large complementary range of solutions to fit with your needs, such as hose clamps and retaining products. We are focus on new development for WATER MANAGEMENT market. Our purpose is to deliver high quality solutions to respond to this mega trend sector.

ADDITIONAL SOLUTIONS

● NORMACLAMP® GBS



NORMACLAMP® GBS clamps are primarily used in the field of commercial and special vehicle construction: fastening suction and compressed air hoses with steel or plastic reinforcement and high degrees of Shore hardness.

ADVANTAGES

- Failure torques improved twice over
- Band tensile force levels improved three times over

TECHNICAL DATA

Material: W1, W2, W3, W4, W5
Clamping range: 17-19 mm to 239-252 mm

● NORMACLAMP® TORRO®



NORMACLAMP® TORRO® hose clips are specially suitable for applications under high mechanical loads. The distinguishing feature of the NORMACLAMP® TORRO® is the asymmetrical construction.

ADVANTAGES

- Multi-range hose clamp
- Clamping ranges in acc. with DIN 3017:
8-16 mm to 140-160 mm
- Larger diameters available on request

TECHNICAL DATA

Material: W1, W2, W3, W4, W5
From now on, no chromium (VI) to be used for coating purposes

● NORMACLAMP® S/SP



Thanks to their robust clamping brackets structure featuring metric bolts, NORMACLAMP® S/SP clamps provide a high level of clamping force.

ADVANTAGES

- High level of clamping force
- Even contact pressure
- Elbow fittings, brackets or lugs can be attached
- Clamps can be fitted with a rubber profile in order to absorb vibrations and protect against the ingress of creeping water

TECHNICAL DATA

Material: W1, W5
According to DIN 3016

NORMA INFRASTRUCTURE

MARKET DEVELOPMENT



Water Management market is a huge increasing market due to urbanization, scarcity and environmental protection.

NORMA Group has skills for supplying connecting solutions for water delivery and distribution industry.

NORMA INFRASTRUCTURE will take benefits of this range.



The Construction market is one of the core business for NORMA INFRASTRUCTURE.

We are developing connecting solutions for sewer construction and which allow adaptation between large diameters differences without the need for compensation rings.

GENERAL INFORMATION

INSTALLATION

For couplings installations, the following information must be observed:

- Remove burrs and clean pipe ends. Damage such as scratches, cracks, etc. or coatings such as paint, rust, etc. must be removed from the sealing lip area.
- Mark half width of the coupling on both pipe ends.
- Slide couplings over pipe ends and align to the pipe marks. Tighten bolts slightly and alternately with ratchet spanner or screwdriver. Do not rotate coupling any further once its teeth have engaged with the pipe. Tighten bolts alternately to a defined torque with a torque wrench (see details on coupling label). Never tighten bolts to more than the specified torque. If leaks occur after fitting, remove coupling and run steps again.

For more detailed information, please refer to installations guidelines include in products packaging.

WARRANTY

Our products range follow legal warranties, for more information please contact your local dealer or NORMA representatives.

CONTACT

For any questions, please send an email to the following address :
infrastructure.info@normagroup.com

Reproduction rights are reserved for all countries: any reproduction, even partial, cannot take place without the prior written consent of Norma.

We are constantly adapting our products to keep up with user needs and technological developments, which is why the models presented in this catalogue, as well as the compositions (representations, photographs, specifications, dimensions and weights) can be modified or deleted without notice and without obligation on our part to make the changes on products previously sold.

The operational tips in this catalogue do not replace the Goode Practices or the legal and regulatory provisions applicable to safety. Reference to standards in force as of 01/02/2013 is not a contractual commitment.



CONTACT

infrastructure.info@normagroup.com

ADRESS

NORMA Group
Edisson Strasse 4
63477 Maintal
GERMANY



1-7Z-6-121101-SE

www.normagroup.com